

## **ADDENDUM #5**

**FOR**

### **RFP – Design/Build RFP for Video Display Upgrades**

**Vendor and contractors to provide Best and Final Pricing based on the revised drawings and proposal forms attached.**

**(1) Attachments:**

**(a) Revised Drawings and Renderings:**

**(i) PCCA Concept Renderings (12.05.24): (54 Pages)**

**(ii) IDF Locations & Signal Flow Diagram: (5 Pages)**

**(iii) PCCA Display Upgrade Proposal Form (12.05.24): (Excel File)**

#### **Best & Final Anticipated Schedule**

**Element**

**Completed By**

**Site Tour Date:**

**Friday, January 24, 2025 (1:00 PM)**

**All Questions Due:**

**Thursday, January 30, 2025 (4:00 PM)**

**Proposals Due:**

**Friday, February 7, 2025 by (1:00 PM)**



LED	QTY	IDF	IDF (option)	Power
1.1	1	IDF-YA	IDF-XB	3A/110V
1.4	2	IDF-YA	IDF-XB	6A/110V
1.17	1	IDF-EI		3A/110V
1.17	1	NEW IDF (EX-Hall F)		3A/110V
1.5	1	IDF-XC	IDF-XI	3A/110V
1.6	2	IDF-XC	IDF-XI	6A/110V
1.22	1	IDF-P		3A/110V
1.1	1	IDF-O		3A/110V
1.19	1	IDF-O		3A/110V
1.7B	1	IDF-O		3A/110V
1.9	1	IDF-O		3A/110V
3.8	2	IDF-EE	IDF-FF	6A/110V
1.8	1	IDF-EE	IDF-FF	3A/110V
1.2	1	IDF-EE	IDF-FF	3A/110V
1.18B	1	IDF-EE	IDF-FF	3A/110V
1.11 A-G	7	IDF-HH	IDF-GG	21A/110V
3.7 North	3	IDF-XL		9A/110V
3.7 South	3	IDF-XM		9A/110V

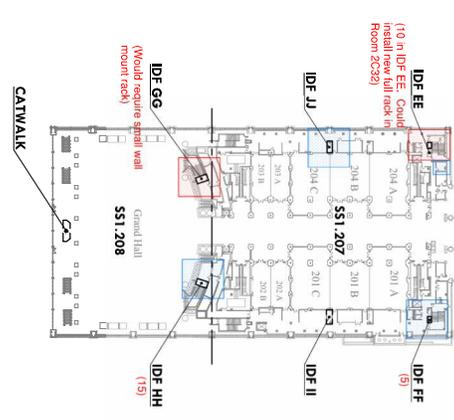
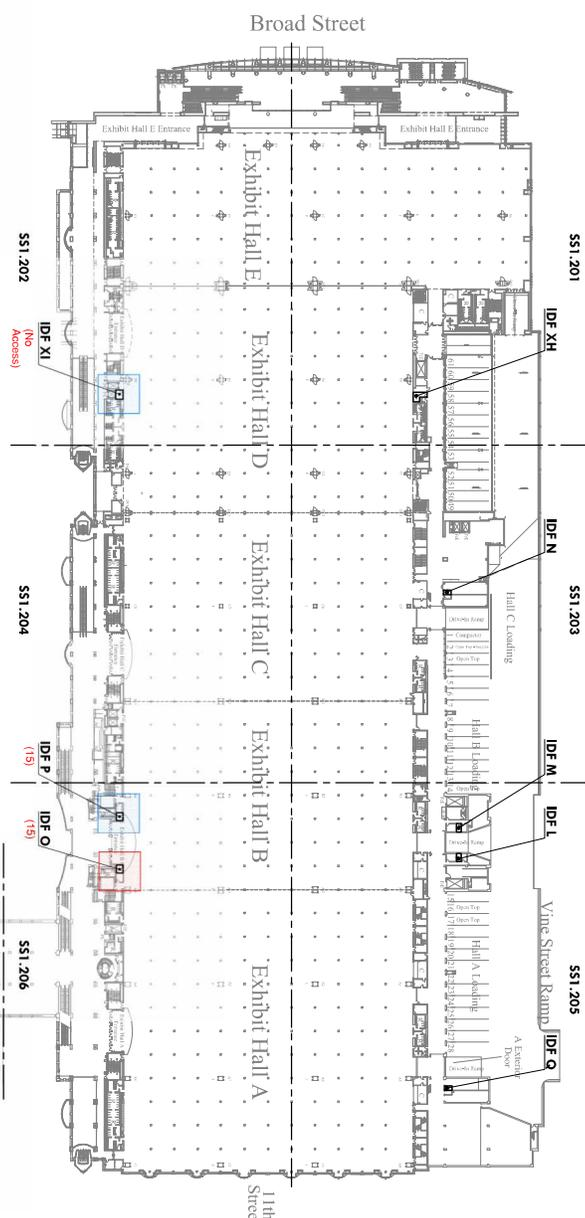

LEVEL 2 OVERALL KEY PLAN  
Scale: 1/8" = 1'-0"

**ARORA**  
ARORA ENGINEERS, INC.  
1600 MARKET STREET, SUITE 1100  
PHILADELPHIA, PA 19103  
215.572.1345

Architect

Civil Engineer

Structural Engineer

100% SUBMISSION

Project Number: 128620.001

Date: 2021-08-24

Drawn By: 18

Checked By: EH

Scale: AS NOTED

**PCCA W/FI UPGRADES**  
1150 ARCH STREET  
PHILADELPHIA, PA 19107  
CONVENTION CENTER  
ADMINISTRATIVE CENTER

Revision:

NO.	DESCRIPTION	DATE

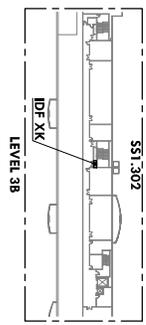
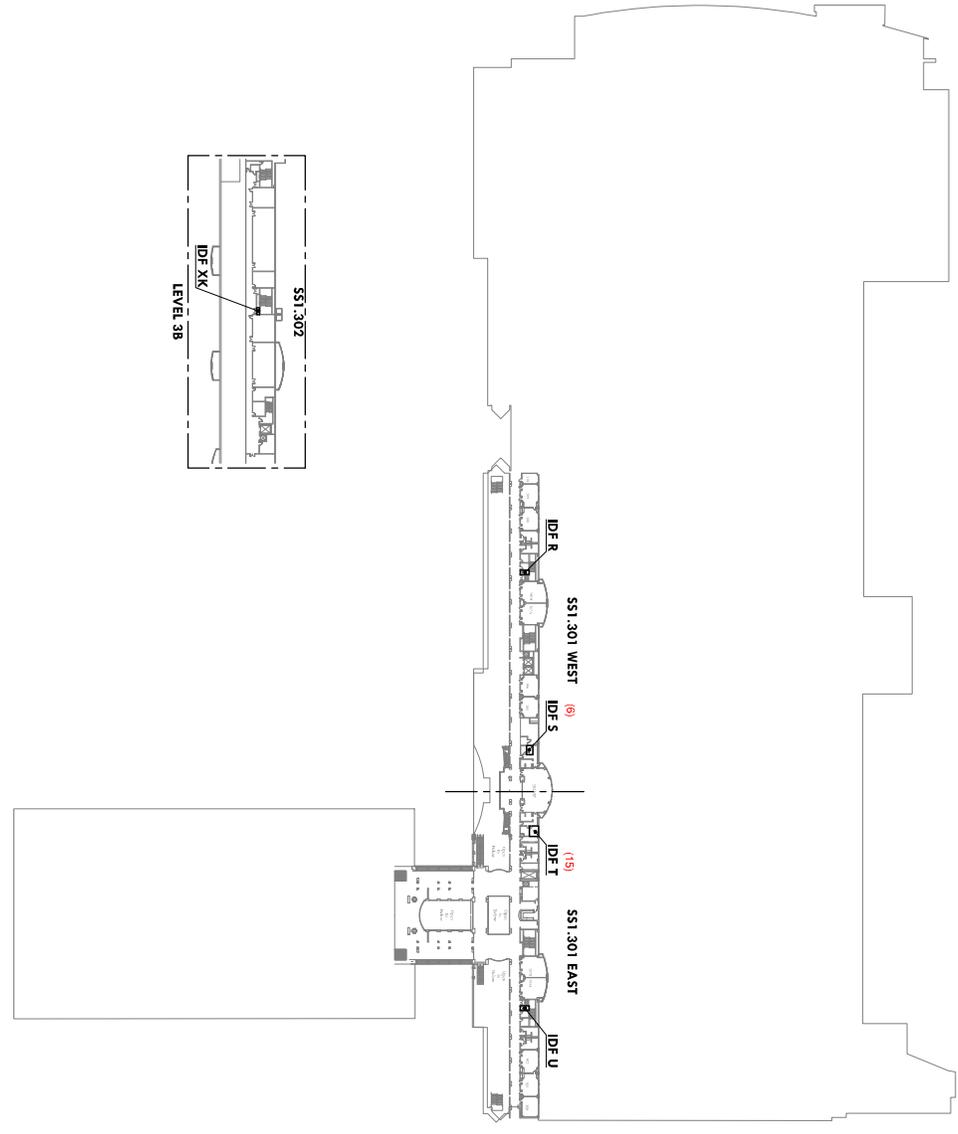

LEVEL 3 OVERALL KEY PLAN  
Scale: 1/8" = 1'-0"

**ARORA**  
ARORA ENGINEERS, INC.  
1400 MARKET STREET, SUITE 200  
PHILADELPHIA, PA 19103  
215.572.1345

Architect

Civil Engineer

Structural Engineer



Key Plan  
Scale: 1/8" = 1'-0"

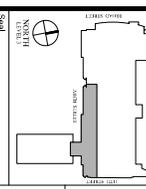

Revisions:

NO.	DESCRIPTION	DATE

**PCCA WIFI UPGRADES**  
110 ARCH STREET  
PHILADELPHIA, PA 19107  
CONVENTION CENTER  
ADMINISTRATIVE (CC20)

**LEVEL 3 OVERALL KEY PLAN**

Project Number: 128620.001  
Date: 2021.08.29  
Drawn By: TH  
Checked By: EH

SSI 300

100% SUBMISSION  
AS NOTED

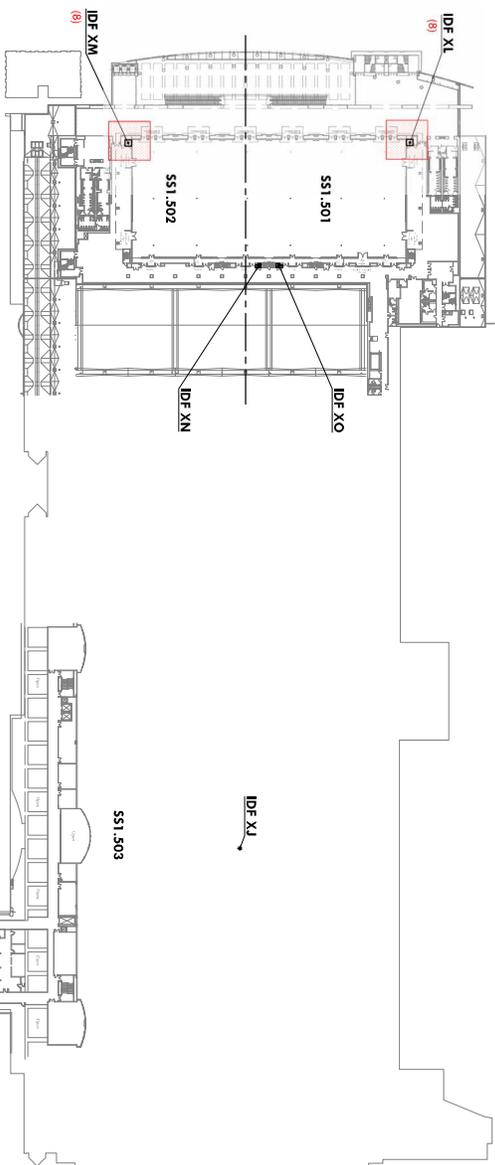

LED	QTY	IDF	IDF (option)	Power
1.1	1	IDF XA	IDF XB	3A/110V
1.4	2	IDF XA	IDF XB	6A/110V
1.17	1	IDF EI		3A/110V
1.17	1	NEW IDF	EX Hall F	3A/110V
1.5	1	IDF XC	IDF XI	3A/110V
1.6	2	IDF XC	IDF XI	6A/110V
1.22	1	IDF P		3A/110V
1.1	1	IDF O		3A/110V
1.19	1	IDF O		3A/110V
1.7B	1	IDF O		3A/110V
1.9	1	IDF O		3A/110V
3.8	2	IDF EE	IDF FF	6A/110V
1.8	1	IDF EE	IDF FF	3A/110V
1.2	1	IDF EE	IDF FF	3A/110V
1.8B	1	IDF EE	IDF FF	3A/110V
1.11 A-G	7	IDF HH	IDF GG	21A/110V
3.7 North	3	IDF XL		9A/110V
3.7 South	3	IDF XM		9A/110V

LEVEL 5 OVERALL KEY PLAN  
Scale: 1/8" = 1'-0"

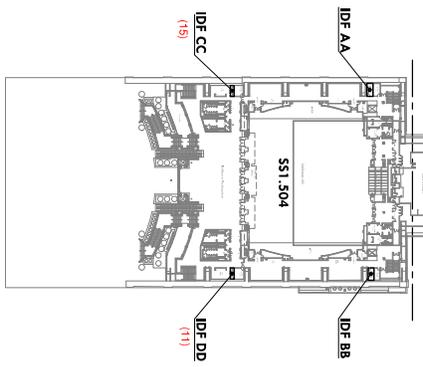

**ARORA**  
ARORA ENGINEERS, INC.  
1600 MARKET STREET, SUITE 1100  
PHILADELPHIA, PA 19103  
215.572.1345

Architect	
Structural Engineer	
Civil Engineer	
MEP Engineer	

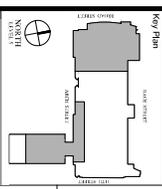

NO.	DESCRIPTION	DATE

**PCCA WIFI UPGRADES**  
110 ARCH STREET  
PHILADELPHIA, PA 19107  
CONVENTION CENTER  
ADMINISTRATIVE CENTER

Project Number	128620.001
Date	2021.08.28
Drawn By	TH
Checked By	EH
Scale	AS NOTED

100% SUBMISSION

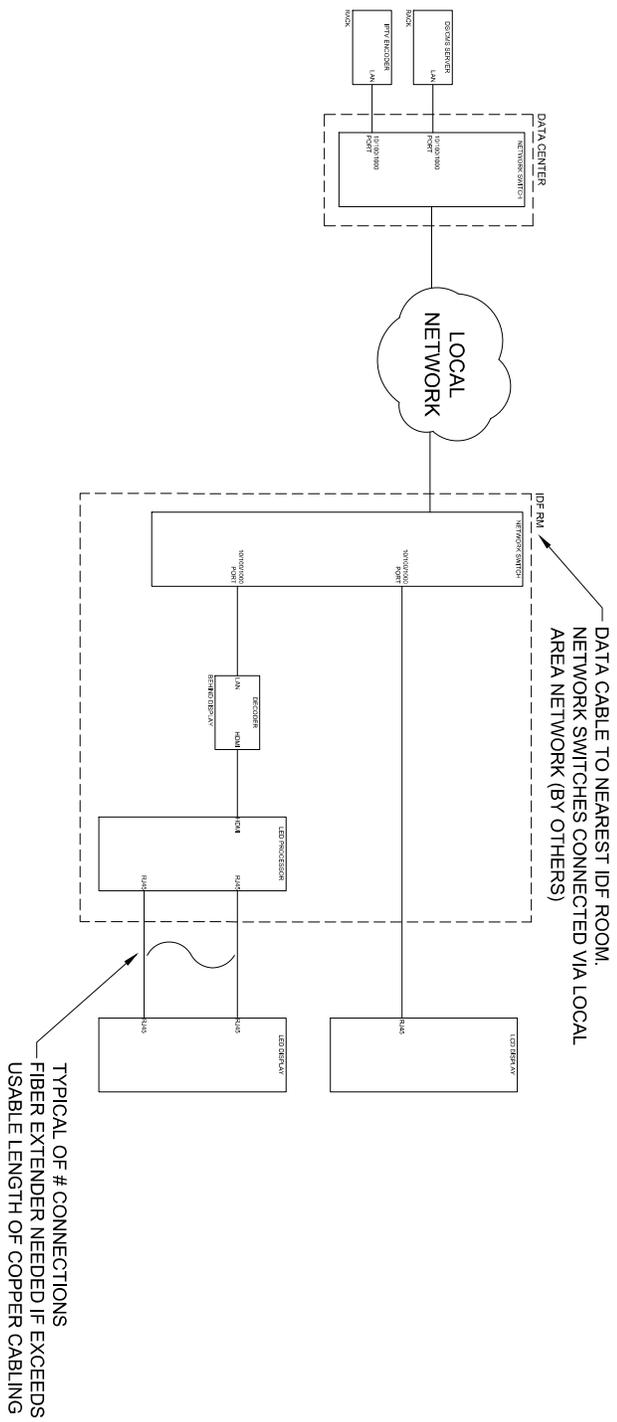

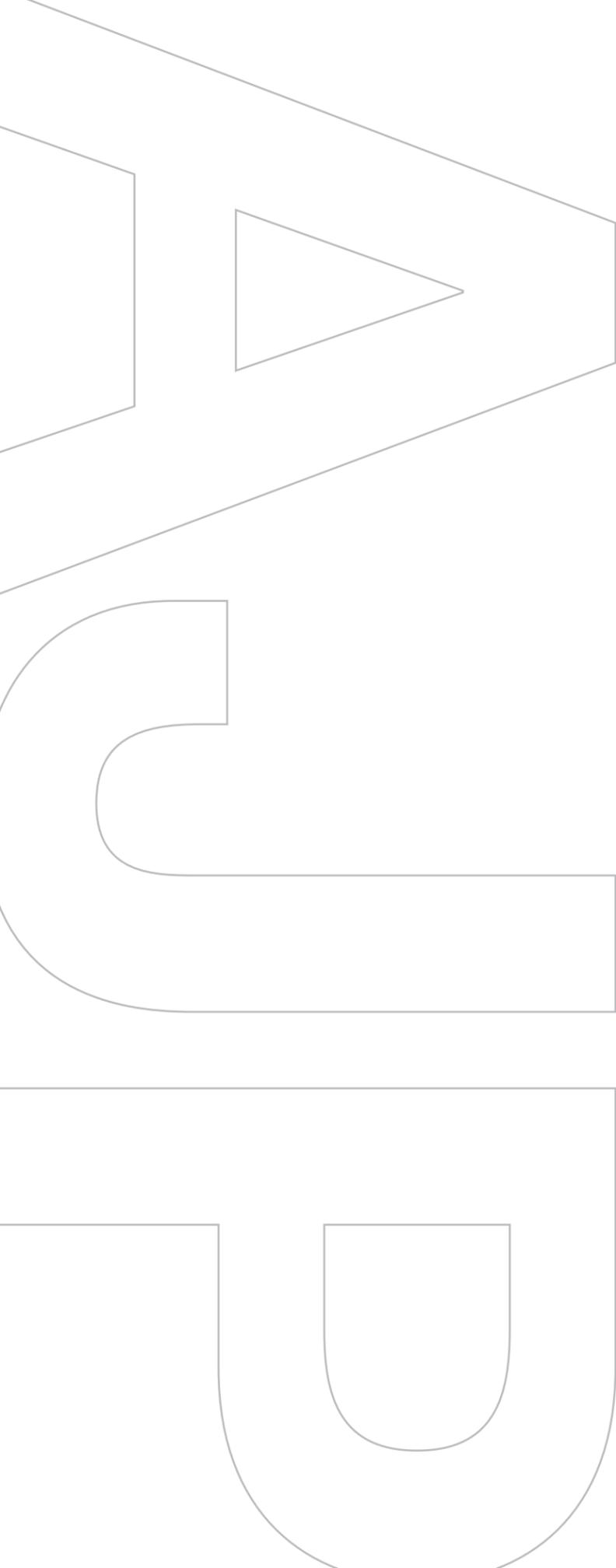

# ANTHONY JAMES PARTNERS.com

---

OWNER'S REPRESENTATIVE | TECHNOLOGY CONSULTANT

---

## PENNSYLVANIA CONVENTION CENTER CONCEPT RENDERINGS

12.05.24

**\*ASSET REQUIRES FIELD SURVEY TO DETERMINE SIZING PRIOR TO FABRICATION OR INSTALLATION. DIMENSIONS NOTED IN THIS DOCUMENT ARE FOR ESTIMATION PURPOSES ONLY. VENDOR IS RESPONSIBLE FOR ANY INCONSISTENCIES BETWEEN CONCEPTS AND FIELD-VERIFIED DIMENSIONS.**

This artwork is protected under federal and international copyright law. Express permission from Anthony James Partners (AJP) is required for reproduction. Renderings are for the exclusive use of designated clients, associates and AJP. These renderings do not represent fabrication or structural engineer-certified or stamped documents. Monitor and/or printer calibration may impair visual accuracy of specified colors.

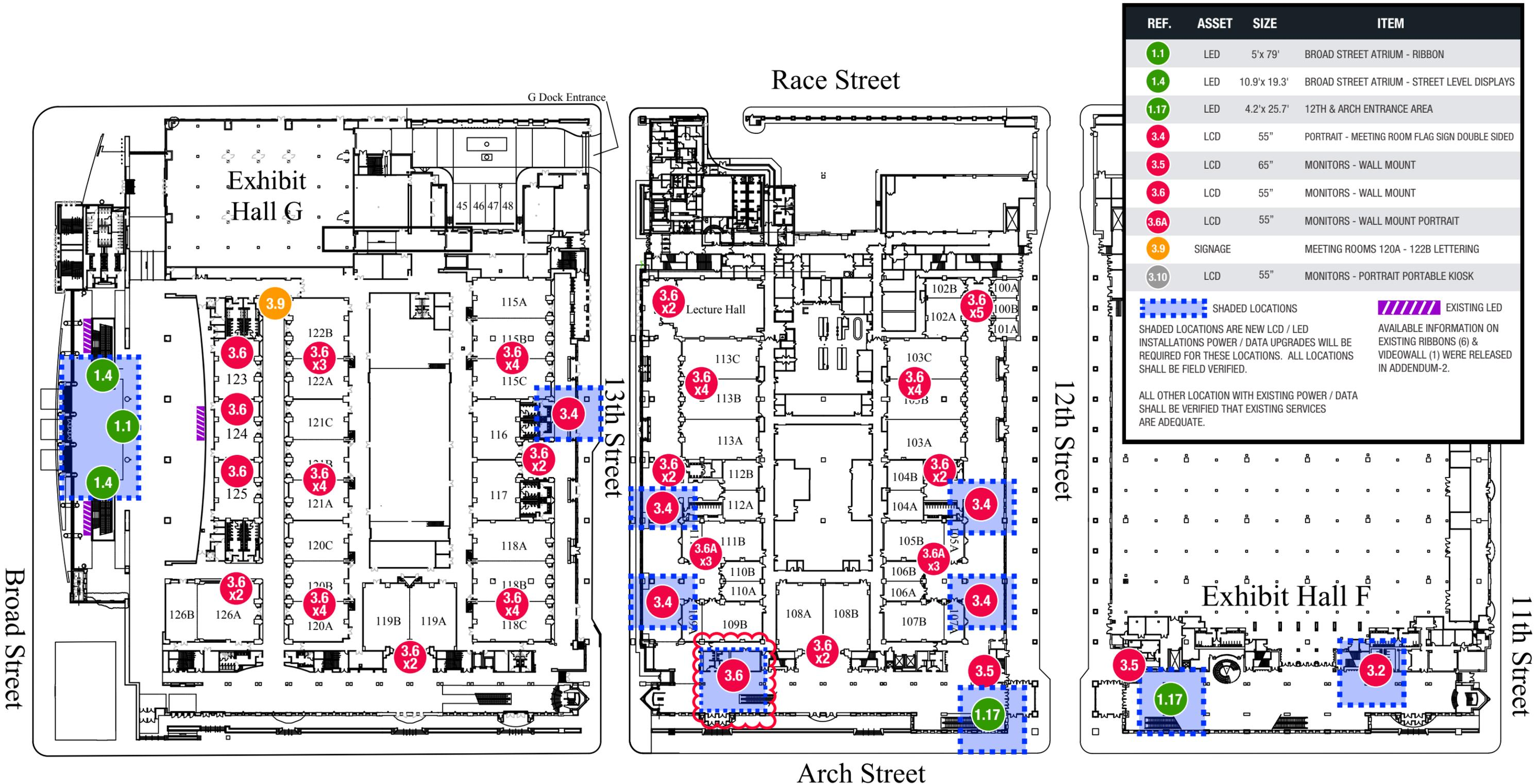

**DISPLAY KEY STREET LEVEL**

**ANTHONY JAMES PARTNERS**

3900 WESTERRE PARKWAY, SUITE 300 RICHMOND, VIRGINIA 23233 804.727.0070 www.anthonijamespartners.com

*\*ASSET REQUIRES FIELD SURVEY TO DETERMINE SIZING PRIOR TO FABRICATION OR INSTALLATION. DIMENSIONS NOTED IN THIS DOCUMENT ARE FOR ESTIMATION PURPOSES ONLY. VENDOR IS RESPONSIBLE FOR ANY INCONSISTENCIES BETWEEN CONCEPTS AND FIELD-VERIFIED DIMENSIONS.*

THIS ARTWORK IS PROTECTED UNDER FEDERAL AND INTERNATIONAL COPYRIGHT LAW. EXPRESS PERMISSION FROM ANTHONY JAMES PARTNERS (AJP) IS REQUIRED FOR REPRODUCTION. RENDERINGS ARE FOR THE EXCLUSIVE USE OF DESIGNATED CLIENTS, ASSOCIATES AND AJP. THESE RENDERINGS DO NOT REPRESENT FABRICATION OR STRUCTURAL ENGINEER CERTIFIED OR STAMPED DOCUMENTS. MONITOR AND/OR PRINTER CALIBRATION MAY IMPAIR VISUAL ACCURACY OF SPECIFIED COLORS.

**MUST BE FIELD VERIFIED\***

PENNSYLVANIA CONVENTION CENTER

CONCEPT RENDERING



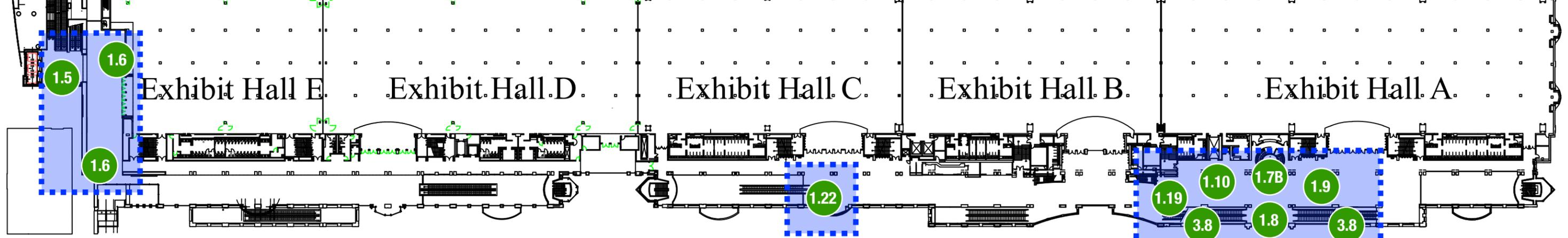

REF.	ASSET	SIZE	ITEM
1.5	LED	28'x 8.6'	ESCALATOR TRIPTYCH
1.6	LED	A-163	HALL "E" DISPLAY
1.7B	LED	4.2'x 30.7'	CROSSROADS NORTH
1.8	LED	4.2'x 30.7'	CROSSROADS SOUTH
1.9	LED	4.2'x 23.6'	CROSSROADS EAST / WEST
1.10	LED	4.2'x 23.6'	CROSSROADS EAST / WEST
1.11 A-G	LED	760 SF	GRAND HALL WALL DISPLAYS
1.18B	LED	4.2'x 30.8'	NORTH FROM GRAND HALL-A
1.19	LED	4.2'x 19.6'	CURVED DISPLAY
1.20	LED	4.2'x 40'	OVERLOOK CAFÉ - CURVED

REF.	ASSET	SIZE	ITEM
1.22	LED	4.2'x 21'	HALL C
3.6	LCD	55"	MONITORS - WALL MOUNT
3.8	LED	2' x 13.2'	WAYFINDING ESCALATOR MOUNT DOUBLE-SIDED

 EXISTING SIGN TO BE REMOVED

 SHADED LOCATIONS

SHADED LOCATIONS ARE NEW LCD / LED INSTALLATIONS. POWER / DATA UPGRADES WILL BE REQUIRED FOR THESE LOCATIONS. ALL LOCATIONS SHALL BE FIELD VERIFIED.

ALL OTHER LOCATION WITH EXISTING POWER / DATA SHALL BE VERIFIED THAT EXISTING SERVICES ARE ADEQUATE.

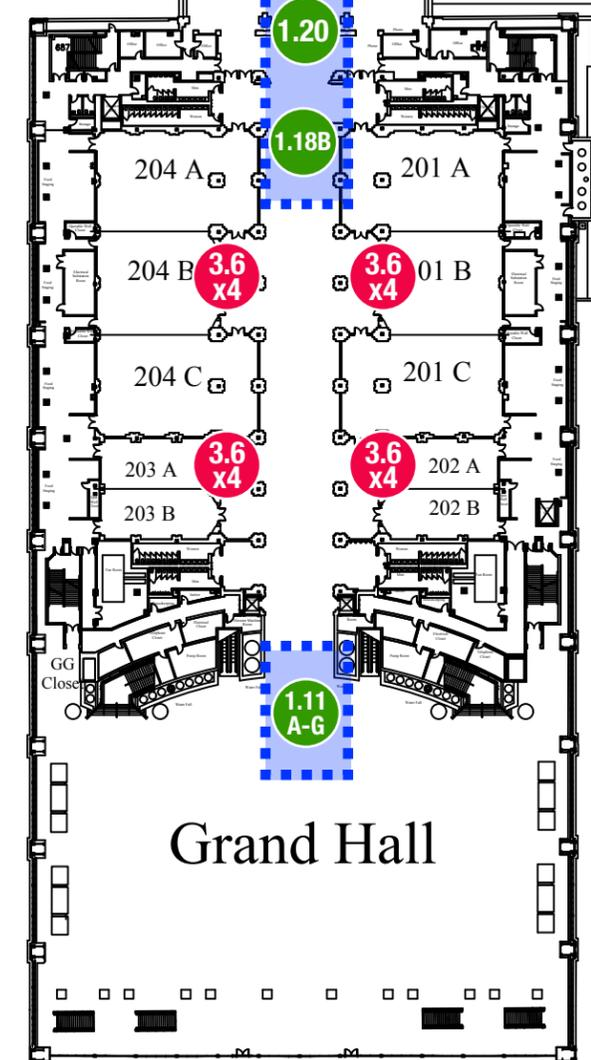

## DISPLAY KEY 200 LEVEL

**ANTHONY  
JAMES  
PARTNERS**

3900 WESTERRE PARKWAY, SUITE 300  
RICHMOND, VIRGINIA 23233  
804.727.0070  
www.anthonijamespartners.com

\*ASSET REQUIRES FIELD SURVEY TO DETERMINE SIZING PRIOR TO FABRICATION OR INSTALLATION. DIMENSIONS NOTED IN THIS DOCUMENT ARE FOR ESTIMATION PURPOSES ONLY. VENDOR IS RESPONSIBLE FOR ANY INCONSISTENCIES BETWEEN CONCEPTS AND FIELD-VERIFIED DIMENSIONS.

THIS ARTWORK IS PROTECTED UNDER FEDERAL AND INTERNATIONAL COPYRIGHT LAW. EXPRESS PERMISSION FROM ANTHONY JAMES PARTNERS (AJP) IS REQUIRED FOR REPRODUCTION. RENDERINGS ARE FOR THE EXCLUSIVE USE OF DESIGNATED CLIENTS, ASSOCIATES AND AJP. THESE RENDERINGS DO NOT REPRESENT FABRICATION OR STRUCTURAL ENGINEER CERTIFIED OR STAMPED DOCUMENTS. MONITOR AND/OR PRINTER CALIBRATION MAY IMPAIR VISUAL ACCURACY OF SPECIFIED COLORS.

**MUST BE FIELD VERIFIED\***

PENNSYLVANIA CONVENTION CENTER

CONCEPT RENDERING

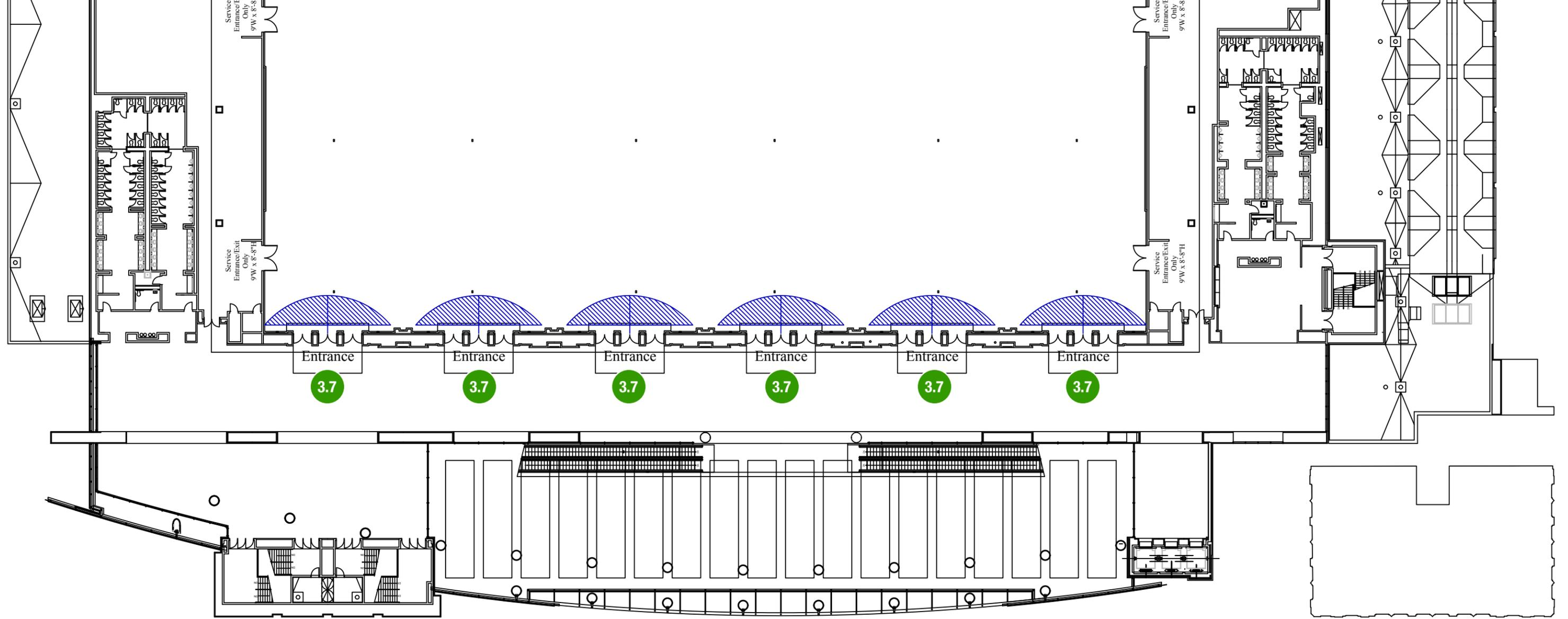

REF.	ASSET	SIZE	ITEM
3.7	LED	2.6'x 12'	BROAD STREET UPPER LEVEL BALLROOM ENTRANCES

## DISPLAY KEY TERRACE BALLROOM

**ANTHONY  
JAMES  
PARTNERS**

3900 WESTERRE PARKWAY, SUITE 300 RICHMOND, VIRGINIA 23233  
804.727.0070 www.anthonijamespartners.com

\*ASSET REQUIRES FIELD SURVEY TO DETERMINE SIZING PRIOR TO FABRICATION OR INSTALLATION. DIMENSIONS NOTED IN THIS DOCUMENT ARE FOR ESTIMATION PURPOSES ONLY. VENDOR IS RESPONSIBLE FOR ANY INCONSISTENCIES BETWEEN CONCEPTS AND FIELD-VERIFIED DIMENSIONS.

THIS ARTWORK IS PROTECTED UNDER FEDERAL AND INTERNATIONAL COPYRIGHT LAW. EXPRESS PERMISSION FROM ANTHONY JAMES PARTNERS (AJP) IS REQUIRED FOR REPRODUCTION. RENDERINGS ARE FOR THE EXCLUSIVE USE OF DESIGNATED CLIENTS, ASSOCIATES AND AJP. THESE RENDERINGS DO NOT REPRESENT FABRICATION OR STRUCTURAL ENGINEER CERTIFIED OR STAMPED DOCUMENTS. MONITOR AND/OR PRINTER CALIBRATION MAY IMPAIR VISUAL ACCURACY OF SPECIFIED COLORS.

**MUST BE FIELD VERIFIED\***

PENNSYLVANIA CONVENTION CENTER

CONCEPT RENDERING



## 1.1 RIBBON BROAD STREET ATRIUM

**ANTHONY  
JAMES  
PARTNERS**

3900 WESTERRE PARKWAY, SUITE 300  
RICHMOND, VIRGINIA 23233

804.727.0070  
[www.anthonyjamespartners.com](http://www.anthonyjamespartners.com)

\*ASSET REQUIRES FIELD SURVEY TO DETERMINE SIZING PRIOR TO FABRICATION OR INSTALLATION. DIMENSIONS NOTED IN THIS DOCUMENT ARE FOR ESTIMATION PURPOSES ONLY. VENDOR IS RESPONSIBLE FOR ANY INCONSISTENCIES BETWEEN CONCEPTS AND FIELD-VERIFIED DIMENSIONS.

THIS ARTWORK IS PROTECTED UNDER FEDERAL AND INTERNATIONAL COPYRIGHT LAW. EXPRESS PERMISSION FROM ANTHONY JAMES PARTNERS (AJP) IS REQUIRED FOR REPRODUCTION. RENDERINGS ARE FOR THE EXCLUSIVE USE OF DESIGNATED CLIENTS, ASSOCIATES AND AJP. THESE RENDERINGS DO NOT REPRESENT FABRICATION OR STRUCTURAL ENGINEER CERTIFIED OR STAMPED DOCUMENTS. MONITOR AND/OR PRINTER CALIBRATION MAY IMPAIR VISUAL ACCURACY OF SPECIFIED COLORS.

\* LED IS OUT OF 16:9 RATIO PER OWNER DIRECTION

**MUST BE FIELD VERIFIED\***

PENNSYLVANIA CONVENTION CENTER

CONCEPT RENDERING

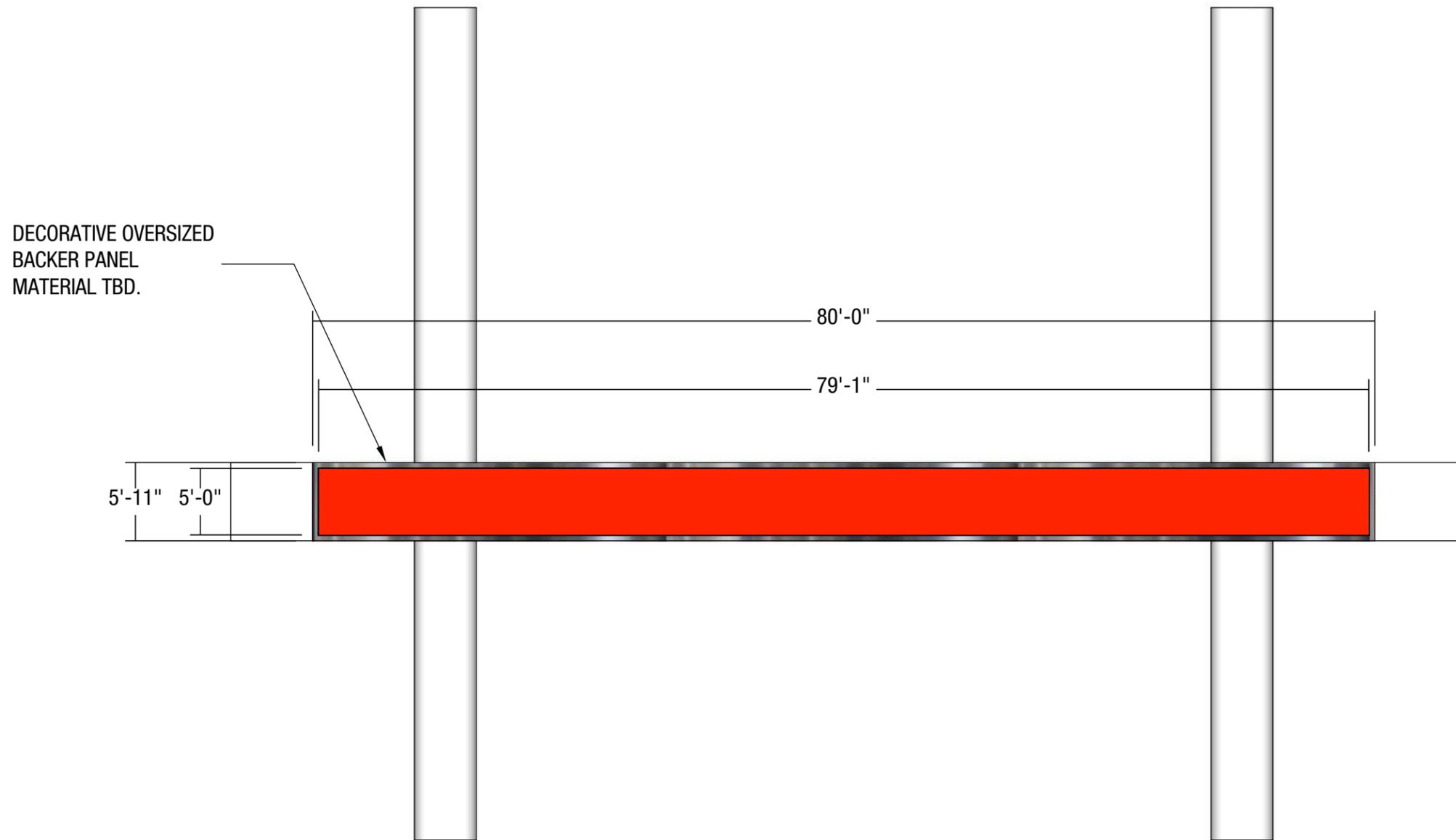

○ LED LAYOUT  
1" = 10'-0"

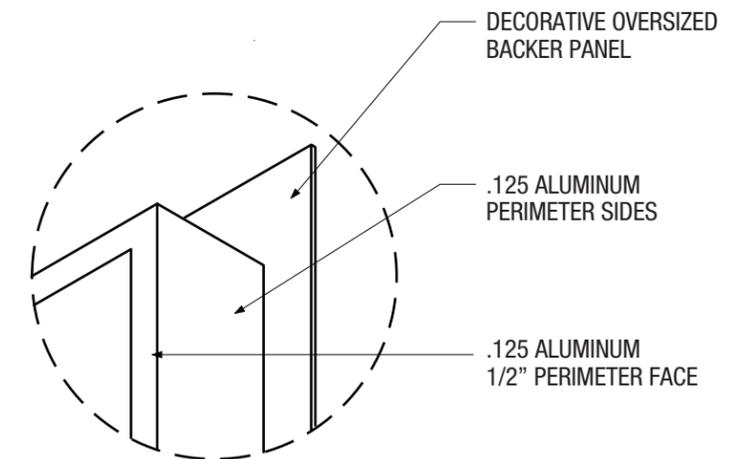

○ LED DETAIL (SURROUND)  
NTS

### 1.1 RIBBON BROAD STREET ATRIUM

**ANTHONY  
JAMES  
PARTNERS**

3900 WESTERRE PARKWAY, SUITE 300 804.727.0070  
RICHMOND, VIRGINIA 23233 www.anthonyjamespartners.com

\*ASSET REQUIRES FIELD SURVEY TO DETERMINE SIZING PRIOR TO FABRICATION OR INSTALLATION. DIMENSIONS NOTED IN THIS DOCUMENT ARE FOR ESTIMATION PURPOSES ONLY. VENDOR IS RESPONSIBLE FOR ANY INCONSISTENCIES BETWEEN CONCEPTS AND FIELD-VERIFIED DIMENSIONS.

THIS ARTWORK IS PROTECTED UNDER FEDERAL AND INTERNATIONAL COPYRIGHT LAW. EXPRESS PERMISSION FROM ANTHONY JAMES PARTNERS (AJP) IS REQUIRED FOR REPRODUCTION. RENDERINGS ARE FOR THE EXCLUSIVE USE OF DESIGNATED CLIENTS, ASSOCIATES AND AJP. THESE RENDERINGS DO NOT REPRESENT FABRICATION OR STRUCTURAL ENGINEER CERTIFIED OR STAMPED DOCUMENTS. MONITOR AND/OR PRINTER CALIBRATION MAY IMPAIR VISUAL ACCURACY OF SPECIFIED COLORS.

\* LED IS OUT OF 16:9 RATIO PER OWNER DIRECTION

**MUST BE FIELD VERIFIED\***

PENNSYLVANIA CONVENTION CENTER

CONCEPT RENDERING



## 1.4 STREET LEVEL DISPLAY BROAD STREET ATRIUM (ALTERNATE 1A)

**ANTHONY  
JAMES  
PARTNERS**

3900 WESTERRE PARKWAY, SUITE 300 804.727.0070  
RICHMOND, VIRGINIA 23233 www.anthonyjamespartners.com

\*ASSET REQUIRES FIELD SURVEY TO DETERMINE SIZING PRIOR TO FABRICATION OR INSTALLATION. DIMENSIONS NOTED IN THIS DOCUMENT ARE FOR ESTIMATION PURPOSES ONLY. VENDOR IS RESPONSIBLE FOR ANY INCONSISTENCIES BETWEEN CONCEPTS AND FIELD-VERIFIED DIMENSIONS.

THIS ARTWORK IS PROTECTED UNDER FEDERAL AND INTERNATIONAL COPYRIGHT LAW. EXPRESS PERMISSION FROM ANTHONY JAMES PARTNERS (AJP) IS REQUIRED FOR REPRODUCTION. RENDERINGS ARE FOR THE EXCLUSIVE USE OF DESIGNATED CLIENTS, ASSOCIATES AND AJP. THESE RENDERINGS DO NOT REPRESENT FABRICATION OR STRUCTURAL ENGINEER CERTIFIED OR STAMPED DOCUMENTS. MONITOR AND/OR PRINTER CALIBRATION MAY IMPAIR VISUAL ACCURACY OF SPECIFIED COLORS.

**MUST BE FIELD VERIFIED\***

PENNSYLVANIA CONVENTION CENTER

CONCEPT RENDERING



**1.4 STREET LEVEL DISPLAY BROAD STREET ATRIUM (ALTERNATE 1B)**

**ANTHONY  
JAMES  
PARTNERS**

3900 WESTERRE PARKWAY, SUITE 300 804.727.0070  
 RICHMOND, VIRGINIA 23233 www.anthonyjamespartners.com

\*ASSET REQUIRES FIELD SURVEY TO DETERMINE SIZING PRIOR TO FABRICATION OR INSTALLATION. DIMENSIONS NOTED IN THIS DOCUMENT ARE FOR ESTIMATION PURPOSES ONLY. VENDOR IS RESPONSIBLE FOR ANY INCONSISTENCIES BETWEEN CONCEPTS AND FIELD-VERIFIED DIMENSIONS.

THIS ARTWORK IS PROTECTED UNDER FEDERAL AND INTERNATIONAL COPYRIGHT LAW. EXPRESS PERMISSION FROM ANTHONY JAMES PARTNERS (AJP) IS REQUIRED FOR REPRODUCTION. RENDERINGS ARE FOR THE EXCLUSIVE USE OF DESIGNATED CLIENTS, ASSOCIATES AND AJP. THESE RENDERINGS DO NOT REPRESENT FABRICATION OR STRUCTURAL ENGINEER CERTIFIED OR STAMPED DOCUMENTS. MONITOR AND/OR PRINTER CALIBRATION MAY IMPAIR VISUAL ACCURACY OF SPECIFIED COLORS.

**MUST BE FIELD VERIFIED\***

PENNSYLVANIA CONVENTION CENTER

CONCEPT RENDERING

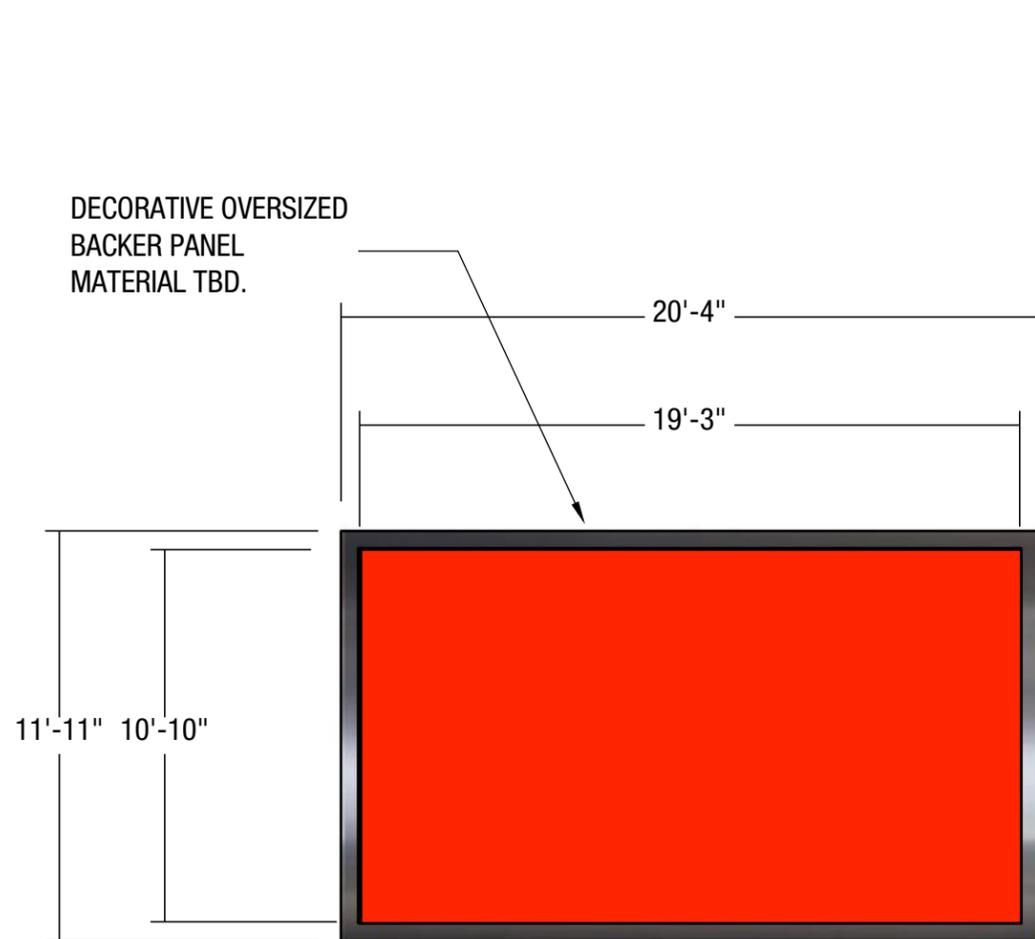

○ LED LAYOUT  
3/16" = 1'-0"

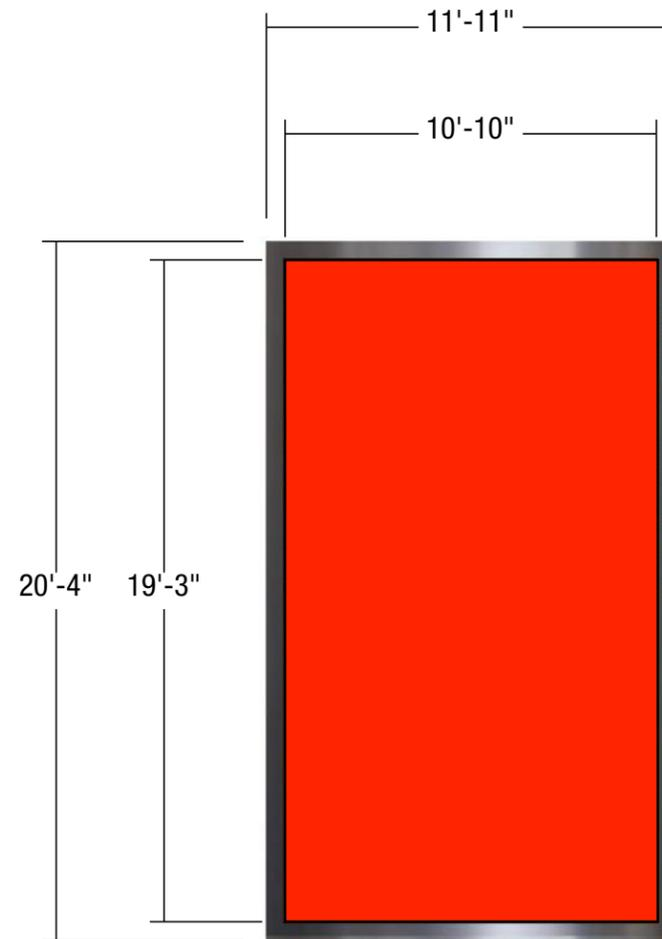

○ LED LAYOUT  
3/16" = 1'-0"

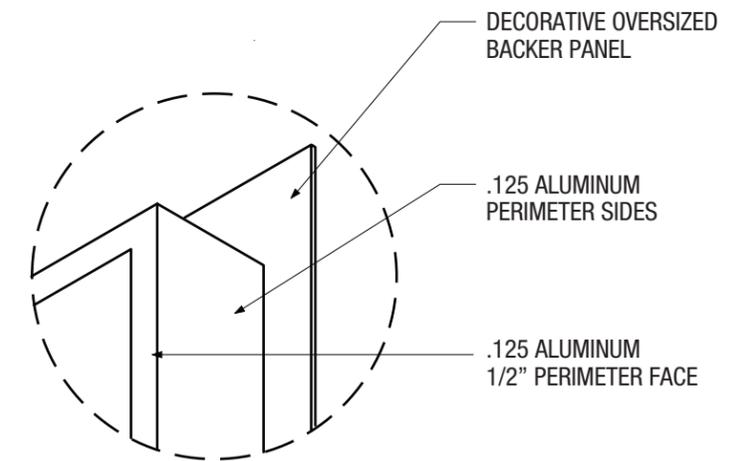

○ LED DETAIL (SURROUND)  
NTS

### 1.4 STREET LEVEL DISPLAY BROAD STREET ATRIUM (ALTERNATE 1A / ALTERNATE 1B)

**ANTHONY  
JAMES  
PARTNERS**

3900 WESTERRE PARKWAY, SUITE 300 804.727.0070  
RICHMOND, VIRGINIA 23233 www.anthonyjamespartners.com

\*ASSET REQUIRES FIELD SURVEY TO DETERMINE SIZING PRIOR TO FABRICATION OR INSTALLATION. DIMENSIONS NOTED IN THIS DOCUMENT ARE FOR ESTIMATION PURPOSES ONLY. VENDOR IS RESPONSIBLE FOR ANY INCONSISTENCIES BETWEEN CONCEPTS AND FIELD-VERIFIED DIMENSIONS.

THIS ARTWORK IS PROTECTED UNDER FEDERAL AND INTERNATIONAL COPYRIGHT LAW. EXPRESS PERMISSION FROM ANTHONY JAMES PARTNERS (AJP) IS REQUIRED FOR REPRODUCTION. RENDERINGS ARE FOR THE EXCLUSIVE USE OF DESIGNATED CLIENTS, ASSOCIATES AND AJP. THESE RENDERINGS DO NOT REPRESENT FABRICATION OR STRUCTURAL ENGINEER CERTIFIED OR STAMPED DOCUMENTS. MONITOR AND/OR PRINTER CALIBRATION MAY IMPAIR VISUAL ACCURACY OF SPECIFIED COLORS.

**MUST BE FIELD VERIFIED\***

PENNSYLVANIA CONVENTION CENTER

CONCEPT RENDERING

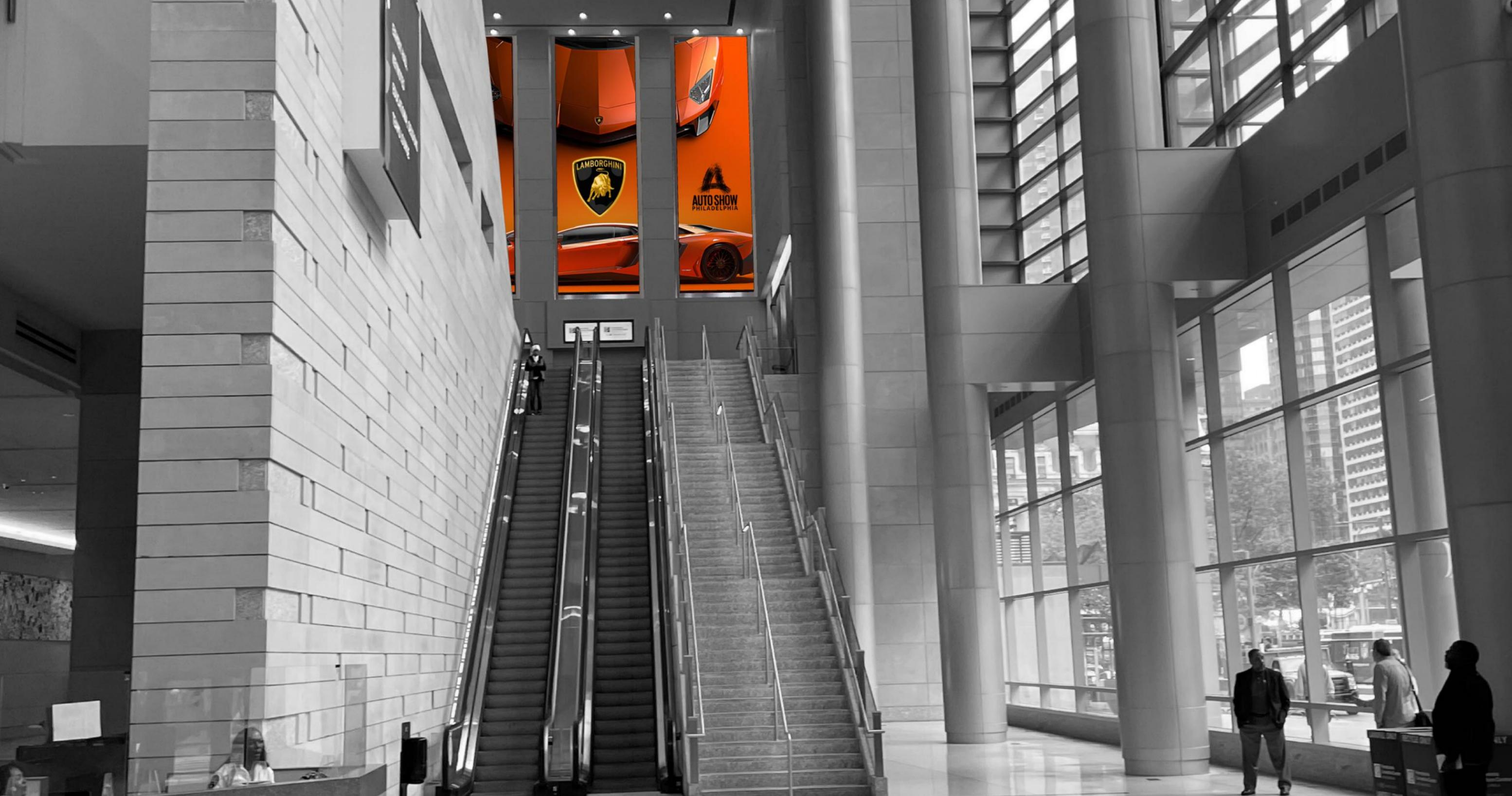

## 1.5 TRIPTYCH ESCALATOR

**ANTHONY  
JAMES  
PARTNERS**

3900 WESTERRE PARKWAY, SUITE 300  
RICHMOND, VIRGINIA 23233

804.727.0070  
www.anthonijamespartners.com

\*ASSET REQUIRES FIELD SURVEY TO DETERMINE SIZING PRIOR TO FABRICATION OR INSTALLATION. DIMENSIONS NOTED IN THIS DOCUMENT ARE FOR ESTIMATION PURPOSES ONLY. VENDOR IS RESPONSIBLE FOR ANY INCONSISTENCIES BETWEEN CONCEPTS AND FIELD-VERIFIED DIMENSIONS.

THIS ARTWORK IS PROTECTED UNDER FEDERAL AND INTERNATIONAL COPYRIGHT LAW. EXPRESS PERMISSION FROM ANTHONY JAMES PARTNERS (AJP) IS REQUIRED FOR REPRODUCTION. RENDERINGS ARE FOR THE EXCLUSIVE USE OF DESIGNATED CLIENTS, ASSOCIATES AND AJP. THESE RENDERINGS DO NOT REPRESENT FABRICATION OR STRUCTURAL ENGINEER CERTIFIED OR STAMPED DOCUMENTS. MONITOR AND/OR PRINTER CALIBRATION MAY IMPAIR VISUAL ACCURACY OF SPECIFIED COLORS.

\* LED IS OUT OF 16:9 RATIO PER OWNER DIRECTION

**MUST BE FIELD VERIFIED\***

PENNSYLVANIA CONVENTION CENTER

CONCEPT RENDERING





## 1.5 TRIPTYCH ESCALATOR

**ANTHONY  
JAMES  
PARTNERS**

3900 WESTERRE PARKWAY, SUITE 300  
RICHMOND, VIRGINIA 23233

804.727.0070  
www.anthonijamespartners.com

\*ASSET REQUIRES FIELD SURVEY TO DETERMINE SIZING PRIOR TO FABRICATION OR INSTALLATION. DIMENSIONS NOTED IN THIS DOCUMENT ARE FOR ESTIMATION PURPOSES ONLY. VENDOR IS RESPONSIBLE FOR ANY INCONSISTENCIES BETWEEN CONCEPTS AND FIELD-VERIFIED DIMENSIONS.

THIS ARTWORK IS PROTECTED UNDER FEDERAL AND INTERNATIONAL COPYRIGHT LAW. EXPRESS PERMISSION FROM ANTHONY JAMES PARTNERS (AJP) IS REQUIRED FOR REPRODUCTION. RENDERINGS ARE FOR THE EXCLUSIVE USE OF DESIGNATED CLIENTS, ASSOCIATES AND AJP. THESE RENDERINGS DO NOT REPRESENT FABRICATION OR STRUCTURAL ENGINEER CERTIFIED OR STAMPED DOCUMENTS. MONITOR AND/OR PRINTER CALIBRATION MAY IMPAIR VISUAL ACCURACY OF SPECIFIED COLORS.

\* LED IS OUT OF 16:9 RATIO PER OWNER DIRECTION

**MUST BE FIELD VERIFIED\***

PENNSYLVANIA CONVENTION CENTER

CONCEPT RENDERING

DECORATIVE OVERSIZED  
BACKER PANEL  
MATERIAL TBD.

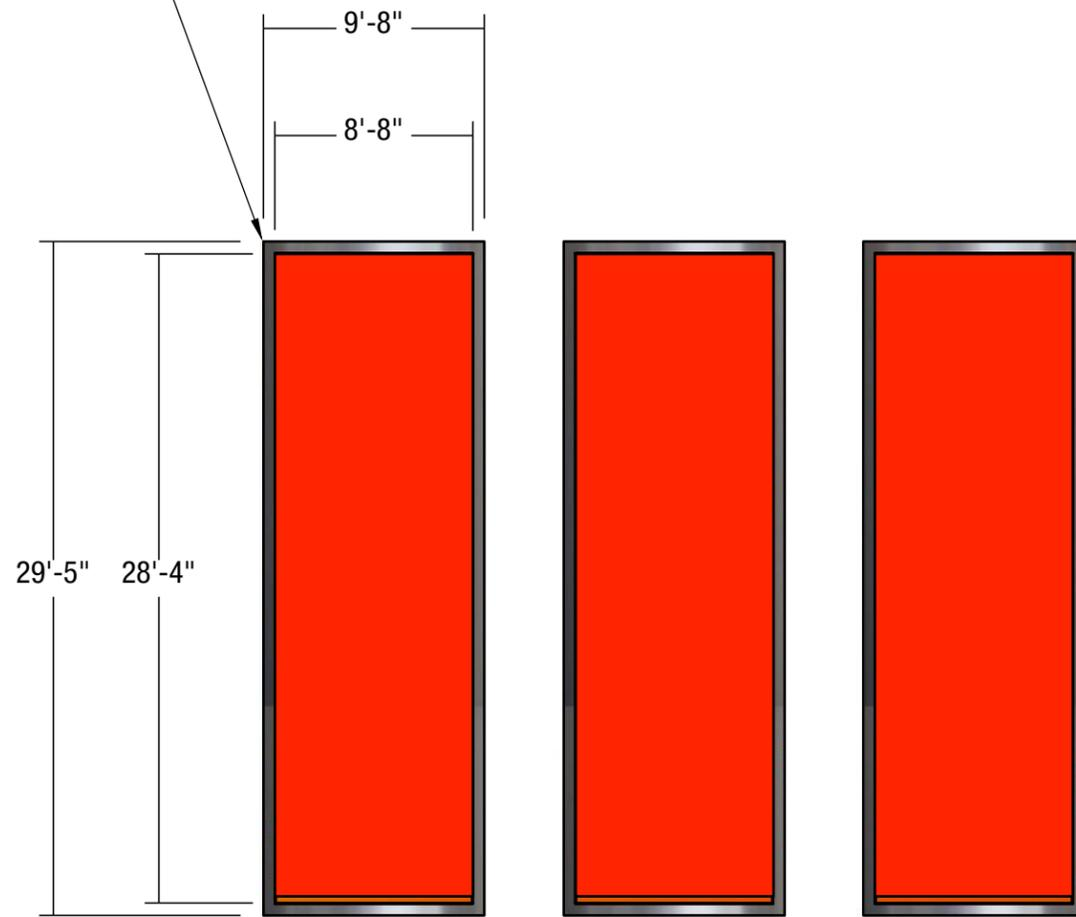

LED LAYOUT  
1/8" = 1'-0"

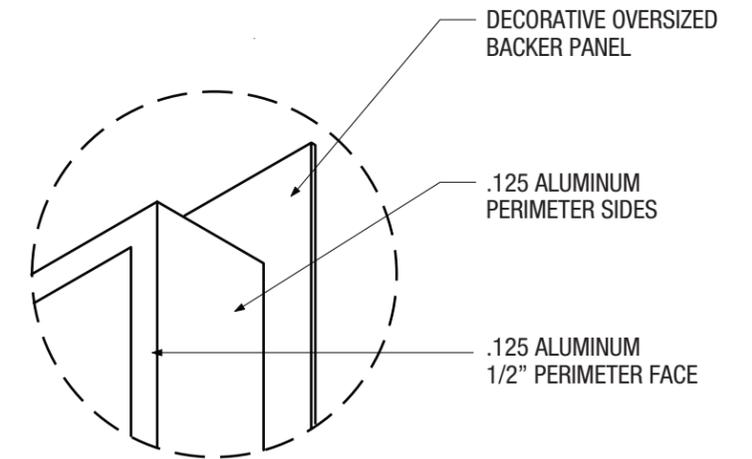

LED DETAIL (SURROUND)  
NTS

## 1.5 TRIPTYCH ESCALATOR

**ANTHONY  
JAMES  
PARTNERS**

3900 WESTERRE PARKWAY, SUITE 300  
RICHMOND, VIRGINIA 23233

804.727.0070  
www.anthonyjamespartners.com

\*ASSET REQUIRES FIELD SURVEY TO DETERMINE SIZING PRIOR TO FABRICATION OR INSTALLATION. DIMENSIONS NOTED IN THIS DOCUMENT ARE FOR ESTIMATION PURPOSES ONLY. VENDOR IS RESPONSIBLE FOR ANY INCONSISTENCIES BETWEEN CONCEPTS AND FIELD-VERIFIED DIMENSIONS.

\* LED IS OUT OF 16:9 RATIO PER OWNER DIRECTION

**MUST BE FIELD VERIFIED\***

PENNSYLVANIA CONVENTION CENTER

THIS ARTWORK IS PROTECTED UNDER FEDERAL AND INTERNATIONAL COPYRIGHT LAW. EXPRESS PERMISSION FROM ANTHONY JAMES PARTNERS (AJP) IS REQUIRED FOR REPRODUCTION. RENDERINGS ARE FOR THE EXCLUSIVE USE OF DESIGNATED CLIENTS, ASSOCIATES AND AJP. THESE RENDERINGS DO NOT REPRESENT FABRICATION OR STRUCTURAL ENGINEER CERTIFIED OR STAMPED DOCUMENTS. MONITOR AND/OR PRINTER CALIBRATION MAY IMPAIR VISUAL ACCURACY OF SPECIFIED COLORS.

CONCEPT RENDERING



## 1.6 DISPLAY HALL E

**ANTHONY  
JAMES  
PARTNERS**

3900 WESTERRE PARKWAY, SUITE 300 804.727.0070  
RICHMOND, VIRGINIA 23233 [www.anthonyjamespartners.com](http://www.anthonyjamespartners.com)

\*ASSET REQUIRES FIELD SURVEY TO DETERMINE SIZING PRIOR TO FABRICATION OR INSTALLATION. DIMENSIONS NOTED IN THIS DOCUMENT ARE FOR ESTIMATION PURPOSES ONLY. VENDOR IS RESPONSIBLE FOR ANY INCONSISTENCIES BETWEEN CONCEPTS AND FIELD-VERIFIED DIMENSIONS.

THIS ARTWORK IS PROTECTED UNDER FEDERAL AND INTERNATIONAL COPYRIGHT LAW. EXPRESS PERMISSION FROM ANTHONY JAMES PARTNERS (AJP) IS REQUIRED FOR REPRODUCTION. RENDERINGS ARE FOR THE EXCLUSIVE USE OF DESIGNATED CLIENTS, ASSOCIATES AND AJP. THESE RENDERINGS DO NOT REPRESENT FABRICATION OR STRUCTURAL ENGINEER CERTIFIED OR STAMPED DOCUMENTS. MONITOR AND/OR PRINTER CALIBRATION MAY IMPAIR VISUAL ACCURACY OF SPECIFIED COLORS.

**MUST BE FIELD VERIFIED\***

PENNSYLVANIA CONVENTION CENTER

CONCEPT RENDERING



## 1.6 DISPLAY HALL E

**ANTHONY  
JAMES  
PARTNERS**

3900 WESTERRE PARKWAY, SUITE 300  
RICHMOND, VIRGINIA 23233

804.727.0070  
www.anthonijamespartners.com

\*ASSET REQUIRES FIELD SURVEY TO DETERMINE SIZING PRIOR TO FABRICATION OR INSTALLATION. DIMENSIONS NOTED IN THIS DOCUMENT ARE FOR ESTIMATION PURPOSES ONLY. VENDOR IS RESPONSIBLE FOR ANY INCONSISTENCIES BETWEEN CONCEPTS AND FIELD-VERIFIED DIMENSIONS.

THIS ARTWORK IS PROTECTED UNDER FEDERAL AND INTERNATIONAL COPYRIGHT LAW. EXPRESS PERMISSION FROM ANTHONY JAMES PARTNERS (AJP) IS REQUIRED FOR REPRODUCTION. RENDERINGS ARE FOR THE EXCLUSIVE USE OF DESIGNATED CLIENTS, ASSOCIATES AND AJP. THESE RENDERINGS DO NOT REPRESENT FABRICATION OR STRUCTURAL ENGINEER CERTIFIED OR STAMPED DOCUMENTS. MONITOR AND/OR PRINTER CALIBRATION MAY IMPAIR VISUAL ACCURACY OF SPECIFIED COLORS.

**MUST BE FIELD VERIFIED\***

PENNSYLVANIA CONVENTION CENTER

CONCEPT RENDERING

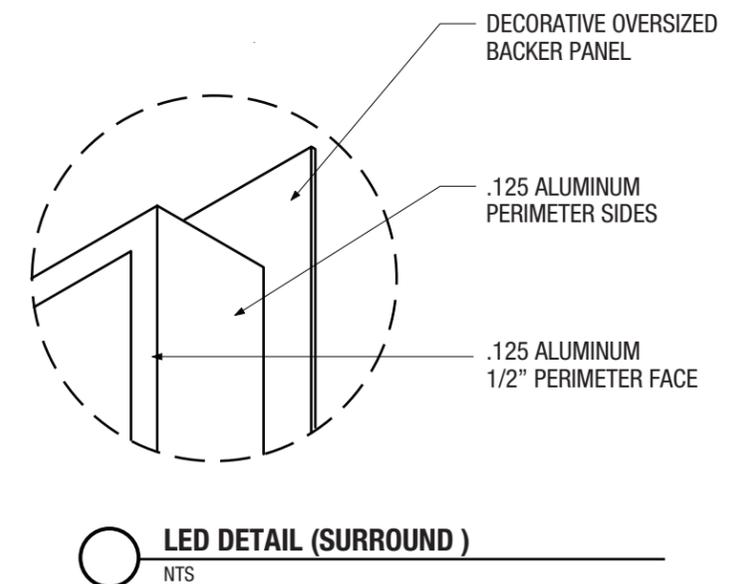
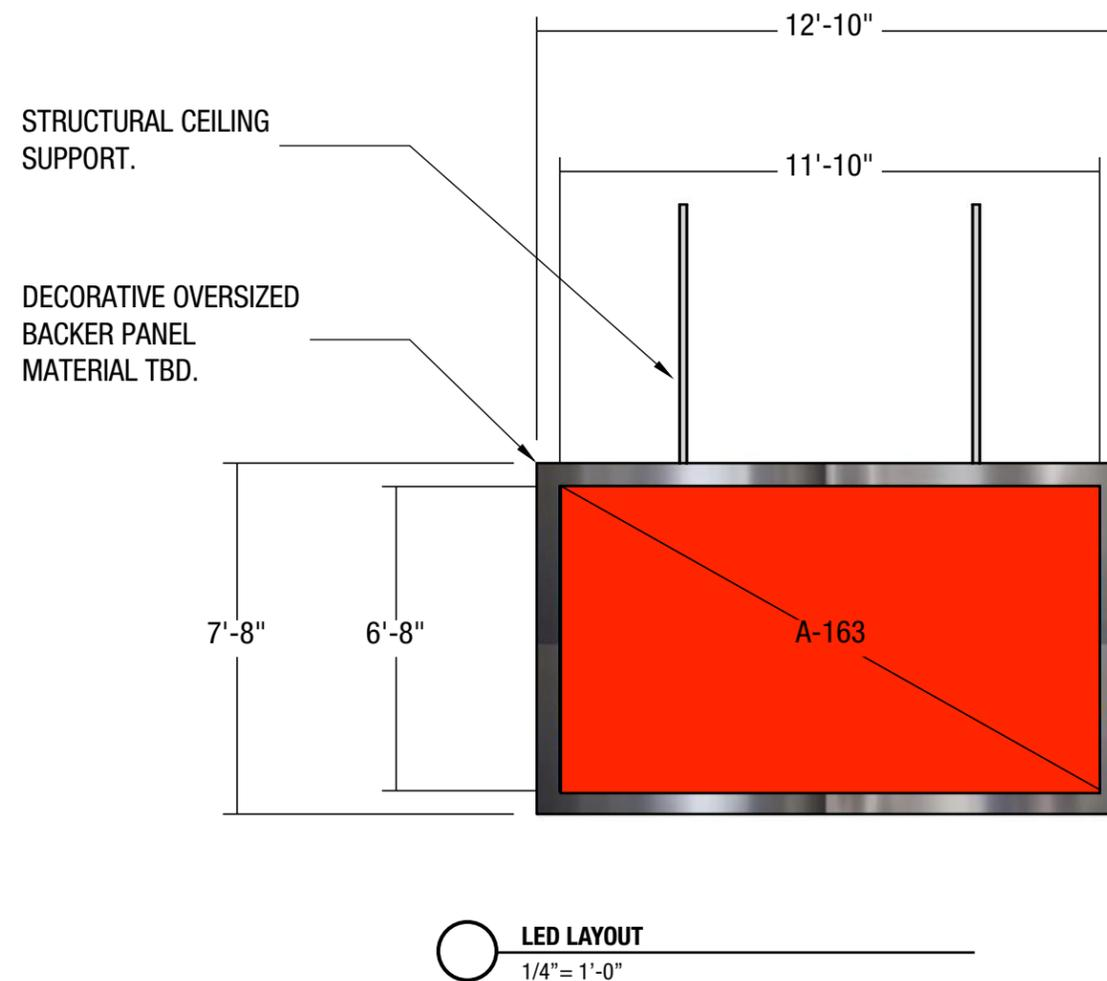

## 1.6 DISPLAY HALL E

**ANTHONY  
JAMES  
PARTNERS**

3900 WESTERRE PARKWAY, SUITE 300 804.727.0070  
RICHMOND, VIRGINIA 23233 www.anthonyjamespartners.com

\*ASSET REQUIRES FIELD SURVEY TO DETERMINE SIZING PRIOR TO FABRICATION OR INSTALLATION. DIMENSIONS NOTED IN THIS DOCUMENT ARE FOR ESTIMATION PURPOSES ONLY. VENDOR IS RESPONSIBLE FOR ANY INCONSISTENCIES BETWEEN CONCEPTS AND FIELD-VERIFIED DIMENSIONS.

THIS ARTWORK IS PROTECTED UNDER FEDERAL AND INTERNATIONAL COPYRIGHT LAW. EXPRESS PERMISSION FROM ANTHONY JAMES PARTNERS (AJP) IS REQUIRED FOR REPRODUCTION. RENDERINGS ARE FOR THE EXCLUSIVE USE OF DESIGNATED CLIENTS, ASSOCIATES AND AJP. THESE RENDERINGS DO NOT REPRESENT FABRICATION OR STRUCTURAL ENGINEER CERTIFIED OR STAMPED DOCUMENTS. MONITOR AND/OR PRINTER CALIBRATION MAY IMPAIR VISUAL ACCURACY OF SPECIFIED COLORS.

**MUST BE FIELD VERIFIED\***

PENNSYLVANIA CONVENTION CENTER

CONCEPT RENDERING



## 1.7B RIBBON CROSSROADS NORTH

**ANTHONY  
JAMES  
PARTNERS**

3900 WESTERRE PARKWAY, SUITE 300  
RICHMOND, VIRGINIA 23233

804.727.0070  
www.anthonyjamespartners.com

\*ASSET REQUIRES FIELD SURVEY TO DETERMINE SIZING PRIOR TO FABRICATION OR INSTALLATION. DIMENSIONS NOTED IN THIS DOCUMENT ARE FOR ESTIMATION PURPOSES ONLY. VENDOR IS RESPONSIBLE FOR ANY INCONSISTENCIES BETWEEN CONCEPTS AND FIELD-VERIFIED DIMENSIONS.

THIS ARTWORK IS PROTECTED UNDER FEDERAL AND INTERNATIONAL COPYRIGHT LAW. EXPRESS PERMISSION FROM ANTHONY JAMES PARTNERS (AJP) IS REQUIRED FOR REPRODUCTION. RENDERINGS ARE FOR THE EXCLUSIVE USE OF DESIGNATED CLIENTS, ASSOCIATES AND AJP. THESE RENDERINGS DO NOT REPRESENT FABRICATION OR STRUCTURAL ENGINEER CERTIFIED OR STAMPED DOCUMENTS. MONITOR AND/OR PRINTER CALIBRATION MAY IMPAIR VISUAL ACCURACY OF SPECIFIED COLORS.

\* LED IS OUT OF 16:9 RATIO PER OWNER DIRECTION

**MUST BE FIELD VERIFIED\***

PENNSYLVANIA CONVENTION CENTER

CONCEPT RENDERING

DECORATIVE OVERSIZED  
BACKER PANEL  
MATERIAL TBD.

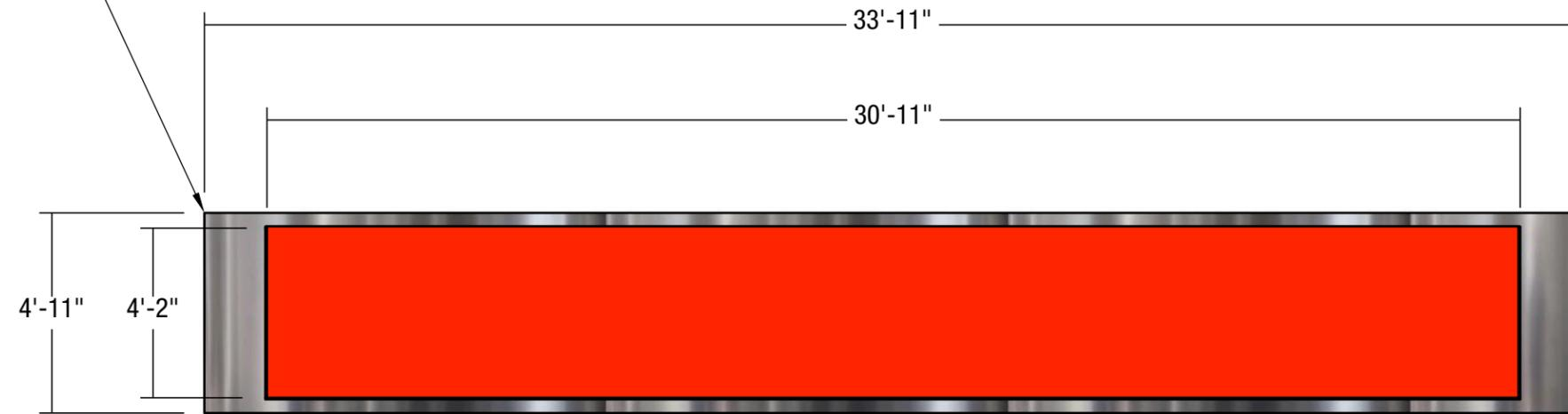

○ LED LAYOUT  
1/4" = 1'-0"

\* RELOCATION OF HVAC VENTS  
& FIRE ALARMS SHALL BE INCLUDED.  
ANY WALL REPAIR & PAINTING  
REQUIRED FROM RELOCATIONS SHALL  
ALSO BE INCLUDED.

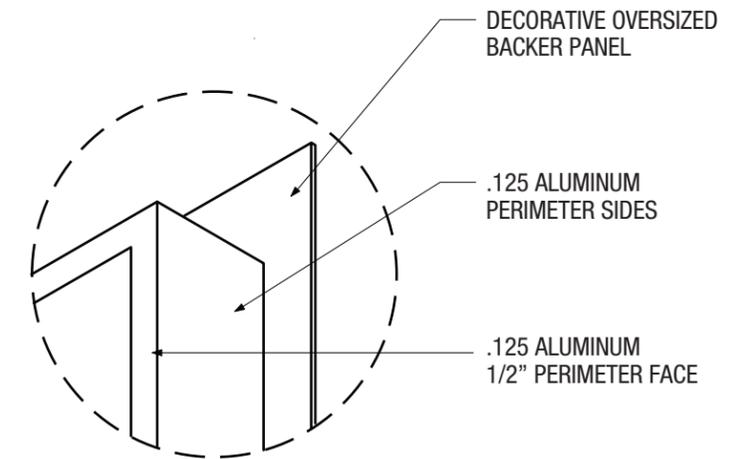

○ LED DETAIL (SURROUND)  
NTS

\* LED IS OUT OF 16:9 RATIO PER OWNER DIRECTION  
**MUST BE FIELD VERIFIED\***

## 1.7B RIBBON CROSSROADS NORTH

**ANTHONY  
JAMES  
PARTNERS**

3900 WESTERRE PARKWAY, SUITE 300 804.727.0070  
RICHMOND, VIRGINIA 23233 www.anthonyjamespartners.com

\*ASSET REQUIRES FIELD SURVEY TO DETERMINE SIZING PRIOR TO FABRICATION OR INSTALLATION. DIMENSIONS NOTED IN THIS DOCUMENT ARE FOR ESTIMATION PURPOSES ONLY. VENDOR IS RESPONSIBLE FOR ANY INCONSISTENCIES BETWEEN CONCEPTS AND FIELD-VERIFIED DIMENSIONS.

PENNSYLVANIA CONVENTION CENTER

THIS ARTWORK IS PROTECTED UNDER FEDERAL AND INTERNATIONAL COPYRIGHT LAW. EXPRESS PERMISSION FROM ANTHONY JAMES PARTNERS (AJP) IS REQUIRED FOR REPRODUCTION. RENDERINGS ARE FOR THE EXCLUSIVE USE OF DESIGNATED CLIENTS, ASSOCIATES AND AJP. THESE RENDERINGS DO NOT REPRESENT FABRICATION OR STRUCTURAL ENGINEER CERTIFIED OR STAMPED DOCUMENTS. MONITOR AND/OR PRINTER CALIBRATION MAY IMPAIR VISUAL ACCURACY OF SPECIFIED COLORS.

CONCEPT RENDERING



## 1.8 RIBBON CROSSROADS SOUTH

**ANTHONY  
JAMES  
PARTNERS**

3900 WESTERRE PARKWAY, SUITE 300  
RICHMOND, VIRGINIA 23233

804.727.0070  
www.anthonyjamespartners.com

\*ASSET REQUIRES FIELD SURVEY TO DETERMINE SIZING PRIOR TO FABRICATION OR INSTALLATION. DIMENSIONS NOTED IN THIS DOCUMENT ARE FOR ESTIMATION PURPOSES ONLY. VENDOR IS RESPONSIBLE FOR ANY INCONSISTENCIES BETWEEN CONCEPTS AND FIELD-VERIFIED DIMENSIONS.

THIS ARTWORK IS PROTECTED UNDER FEDERAL AND INTERNATIONAL COPYRIGHT LAW. EXPRESS PERMISSION FROM ANTHONY JAMES PARTNERS (AJP) IS REQUIRED FOR REPRODUCTION. RENDERINGS ARE FOR THE EXCLUSIVE USE OF DESIGNATED CLIENTS, ASSOCIATES AND AJP. THESE RENDERINGS DO NOT REPRESENT FABRICATION OR STRUCTURAL ENGINEER CERTIFIED OR STAMPED DOCUMENTS. MONITOR AND/OR PRINTER CALIBRATION MAY IMPAIR VISUAL ACCURACY OF SPECIFIED COLORS.

\* LED IS OUT OF 16:9 RATIO PER OWNER DIRECTION

**MUST BE FIELD VERIFIED\***

PENNSYLVANIA CONVENTION CENTER

CONCEPT RENDERING



DECORATIVE OVERSIZED  
BACKER PANEL  
MATERIAL TBD.

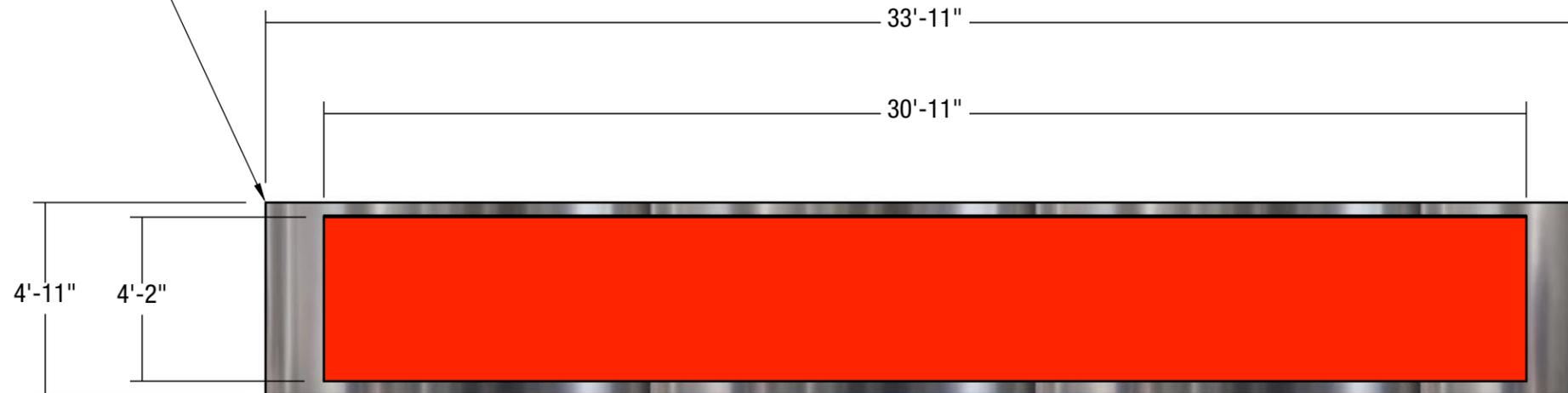

○ LED LAYOUT  
1/4" = 1'-0"

\* RELOCATION OF HVAC VENTS  
& FIRE ALARMS SHALL BE INCLUDED.  
ANY WALL REPAIR & PAINTING  
REQUIRED FROM RELOCATIONS SHALL  
ALSO BE INCLUDED.

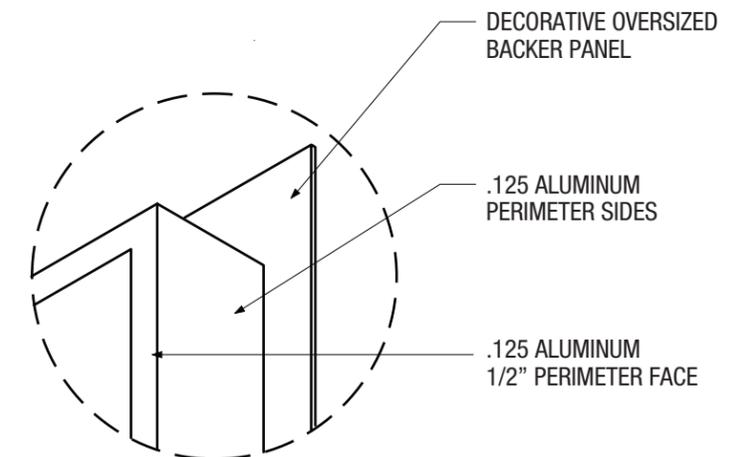

○ LED DETAIL (SURROUND)  
NTS

\* LED IS OUT OF 16:9 RATIO PER OWNER DIRECTION  
**MUST BE FIELD VERIFIED\***

## 1.8 RIBBON CROSSROADS SOUTH

**ANTHONY  
JAMES  
PARTNERS**

3900 WESTERRE PARKWAY, SUITE 300 804.727.0070  
RICHMOND, VIRGINIA 23233 www.anthonyjamespartners.com

\*ASSET REQUIRES FIELD SURVEY TO DETERMINE SIZING PRIOR TO FABRICATION OR INSTALLATION. DIMENSIONS NOTED IN THIS DOCUMENT ARE FOR ESTIMATION PURPOSES ONLY. VENDOR IS RESPONSIBLE FOR ANY INCONSISTENCIES BETWEEN CONCEPTS AND FIELD-VERIFIED DIMENSIONS.

PENNSYLVANIA CONVENTION CENTER

THIS ARTWORK IS PROTECTED UNDER FEDERAL AND INTERNATIONAL COPYRIGHT LAW. EXPRESS PERMISSION FROM ANTHONY JAMES PARTNERS (AJP) IS REQUIRED FOR REPRODUCTION. RENDERINGS ARE FOR THE EXCLUSIVE USE OF DESIGNATED CLIENTS, ASSOCIATES AND AJP. THESE RENDERINGS DO NOT REPRESENT FABRICATION OR STRUCTURAL ENGINEER CERTIFIED OR STAMPED DOCUMENTS. MONITOR AND/OR PRINTER CALIBRATION MAY IMPAIR VISUAL ACCURACY OF SPECIFIED COLORS.

CONCEPT RENDERING



## 1.9 RIBBON CROSSROADS EAST

**ANTHONY  
JAMES  
PARTNERS**

3900 WESTERRE PARKWAY, SUITE 300  
RICHMOND, VIRGINIA 23233

804.727.0070  
www.anthonijamespartners.com

\*ASSET REQUIRES FIELD SURVEY TO DETERMINE SIZING PRIOR TO FABRICATION OR INSTALLATION. DIMENSIONS NOTED IN THIS DOCUMENT ARE FOR ESTIMATION PURPOSES ONLY. VENDOR IS RESPONSIBLE FOR ANY INCONSISTENCIES BETWEEN CONCEPTS AND FIELD-VERIFIED DIMENSIONS.

THIS ARTWORK IS PROTECTED UNDER FEDERAL AND INTERNATIONAL COPYRIGHT LAW. EXPRESS PERMISSION FROM ANTHONY JAMES PARTNERS (AJP) IS REQUIRED FOR REPRODUCTION. RENDERINGS ARE FOR THE EXCLUSIVE USE OF DESIGNATED CLIENTS, ASSOCIATES AND AJP. THESE RENDERINGS DO NOT REPRESENT FABRICATION OR STRUCTURAL ENGINEER CERTIFIED OR STAMPED DOCUMENTS. MONITOR AND/OR PRINTER CALIBRATION MAY IMPAIR VISUAL ACCURACY OF SPECIFIED COLORS.

\* LED IS OUT OF 16:9 RATIO PER OWNER DIRECTION

**MUST BE FIELD VERIFIED\***

PENNSYLVANIA CONVENTION CENTER

CONCEPT RENDERING

DECORATIVE OVERSIZED  
BACKER PANEL  
MATERIAL TBD.



○ LED LAYOUT  
1/4" = 1'-0"

\* RELOCATION OF HVAC VENTS  
& FIRE ALARMS SHALL BE INCLUDED.  
ANY WALL REPAIR & PAINTING  
REQUIRED FROM RELOCATIONS SHALL  
ALSO BE INCLUDED.

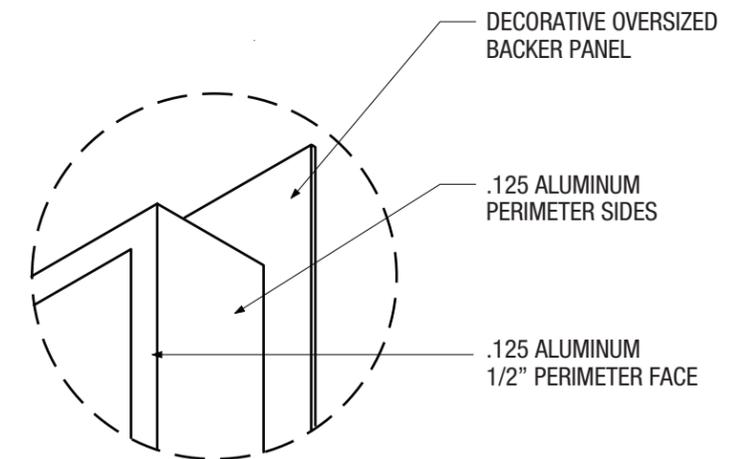

○ LED DETAIL (SURROUND)  
NTS

\* LED IS OUT OF 16:9 RATIO PER OWNER DIRECTION  
**MUST BE FIELD VERIFIED\***

## 1.9 RIBBON CROSSROADS EAST

**ANTHONY  
JAMES  
PARTNERS**

3900 WESTERRE PARKWAY, SUITE 300 804.727.0070  
RICHMOND, VIRGINIA 23233 www.anthonijamespartners.com

\*ASSET REQUIRES FIELD SURVEY TO DETERMINE SIZING PRIOR TO FABRICATION OR INSTALLATION. DIMENSIONS NOTED IN THIS DOCUMENT ARE FOR ESTIMATION PURPOSES ONLY. VENDOR IS RESPONSIBLE FOR ANY INCONSISTENCIES BETWEEN CONCEPTS AND FIELD-VERIFIED DIMENSIONS.

PENNSYLVANIA CONVENTION CENTER

THIS ARTWORK IS PROTECTED UNDER FEDERAL AND INTERNATIONAL COPYRIGHT LAW. EXPRESS PERMISSION FROM ANTHONY JAMES PARTNERS (AJP) IS REQUIRED FOR REPRODUCTION. RENDERINGS ARE FOR THE EXCLUSIVE USE OF DESIGNATED CLIENTS, ASSOCIATES AND AJP. THESE RENDERINGS DO NOT REPRESENT FABRICATION OR STRUCTURAL ENGINEER CERTIFIED OR STAMPED DOCUMENTS. MONITOR AND/OR PRINTER CALIBRATION MAY IMPAIR VISUAL ACCURACY OF SPECIFIED COLORS.

CONCEPT RENDERING



## 1.10 RIBBON CROSSROADS WEST

**ANTHONY  
JAMES  
PARTNERS**

3900 WESTERRE PARKWAY, SUITE 300  
RICHMOND, VIRGINIA 23233

804.727.0070  
www.anthonyjamespartners.com

\*ASSET REQUIRES FIELD SURVEY TO DETERMINE SIZING PRIOR TO FABRICATION OR INSTALLATION. DIMENSIONS NOTED IN THIS DOCUMENT ARE FOR ESTIMATION PURPOSES ONLY. VENDOR IS RESPONSIBLE FOR ANY INCONSISTENCIES BETWEEN CONCEPTS AND FIELD-VERIFIED DIMENSIONS.

THIS ARTWORK IS PROTECTED UNDER FEDERAL AND INTERNATIONAL COPYRIGHT LAW. EXPRESS PERMISSION FROM ANTHONY JAMES PARTNERS (AJP) IS REQUIRED FOR REPRODUCTION. RENDERINGS ARE FOR THE EXCLUSIVE USE OF DESIGNATED CLIENTS, ASSOCIATES AND AJP. THESE RENDERINGS DO NOT REPRESENT FABRICATION OR STRUCTURAL ENGINEER CERTIFIED OR STAMPED DOCUMENTS. MONITOR AND/OR PRINTER CALIBRATION MAY IMPAIR VISUAL ACCURACY OF SPECIFIED COLORS.

\* LED IS OUT OF 16:9 RATIO PER OWNER DIRECTION

**MUST BE FIELD VERIFIED\***

PENNSYLVANIA CONVENTION CENTER

CONCEPT RENDERING

DECORATIVE OVERSIZED  
BACKER PANEL  
MATERIAL TBD.

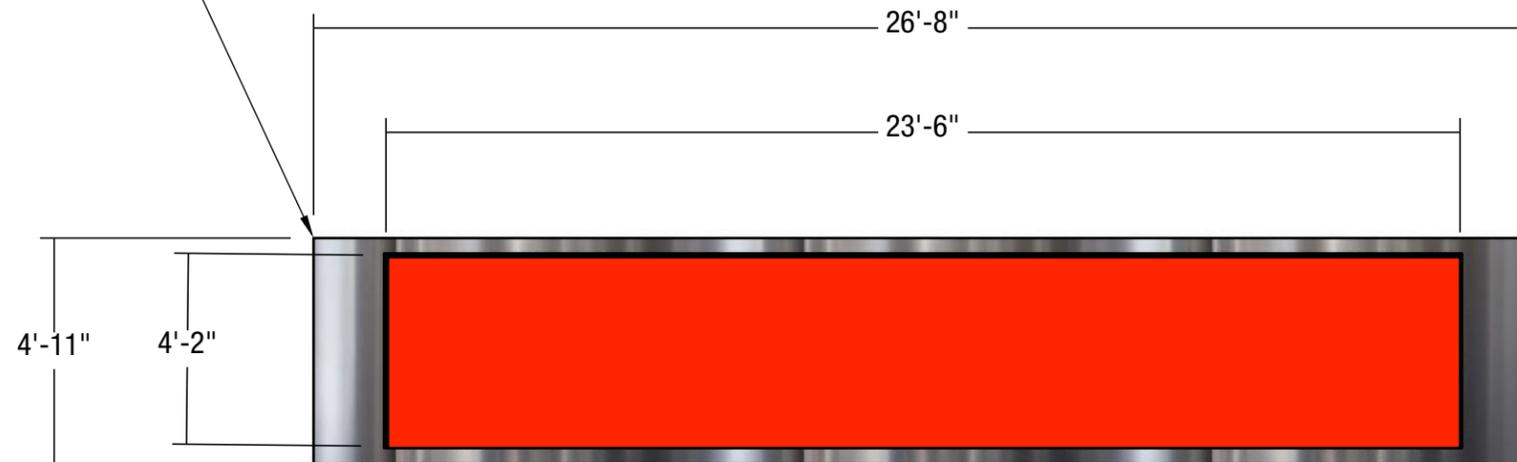

○ LED LAYOUT  
1/4" = 1'-0"

\* RELOCATION OF HVAC VENTS  
& FIRE ALARMS SHALL BE INCLUDED.  
ANY WALL REPAIR & PAINTING  
REQUIRED FROM RELOCATIONS SHALL  
ALSO BE INCLUDED.

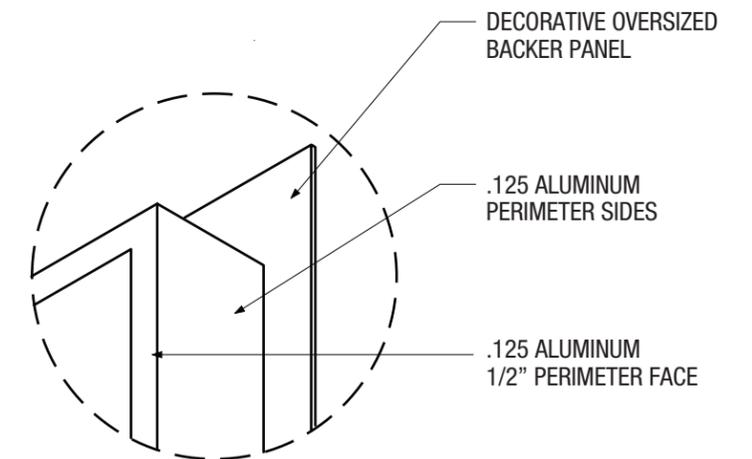

○ LED DETAIL (SURROUND)  
NTS

\* LED IS OUT OF 16:9 RATIO PER OWNER DIRECTION  
**MUST BE FIELD VERIFIED\***

### 1.10 RIBBON CROSSROADS WEST

**ANTHONY  
JAMES  
PARTNERS**

3900 WESTERRE PARKWAY, SUITE 300 804.727.0070  
RICHMOND, VIRGINIA 23233 www.anthonyjamespartners.com

\*ASSET REQUIRES FIELD SURVEY TO DETERMINE SIZING PRIOR TO FABRICATION OR INSTALLATION. DIMENSIONS NOTED IN THIS DOCUMENT ARE FOR ESTIMATION PURPOSES ONLY. VENDOR IS RESPONSIBLE FOR ANY INCONSISTENCIES BETWEEN CONCEPTS AND FIELD-VERIFIED DIMENSIONS.

PENNSYLVANIA CONVENTION CENTER

THIS ARTWORK IS PROTECTED UNDER FEDERAL AND INTERNATIONAL COPYRIGHT LAW. EXPRESS PERMISSION FROM ANTHONY JAMES PARTNERS (AJP) IS REQUIRED FOR REPRODUCTION. RENDERINGS ARE FOR THE EXCLUSIVE USE OF DESIGNATED CLIENTS, ASSOCIATES AND AJP. THESE RENDERINGS DO NOT REPRESENT FABRICATION OR STRUCTURAL ENGINEER CERTIFIED OR STAMPED DOCUMENTS. MONITOR AND/OR PRINTER CALIBRATION MAY IMPAIR VISUAL ACCURACY OF SPECIFIED COLORS.

CONCEPT RENDERING

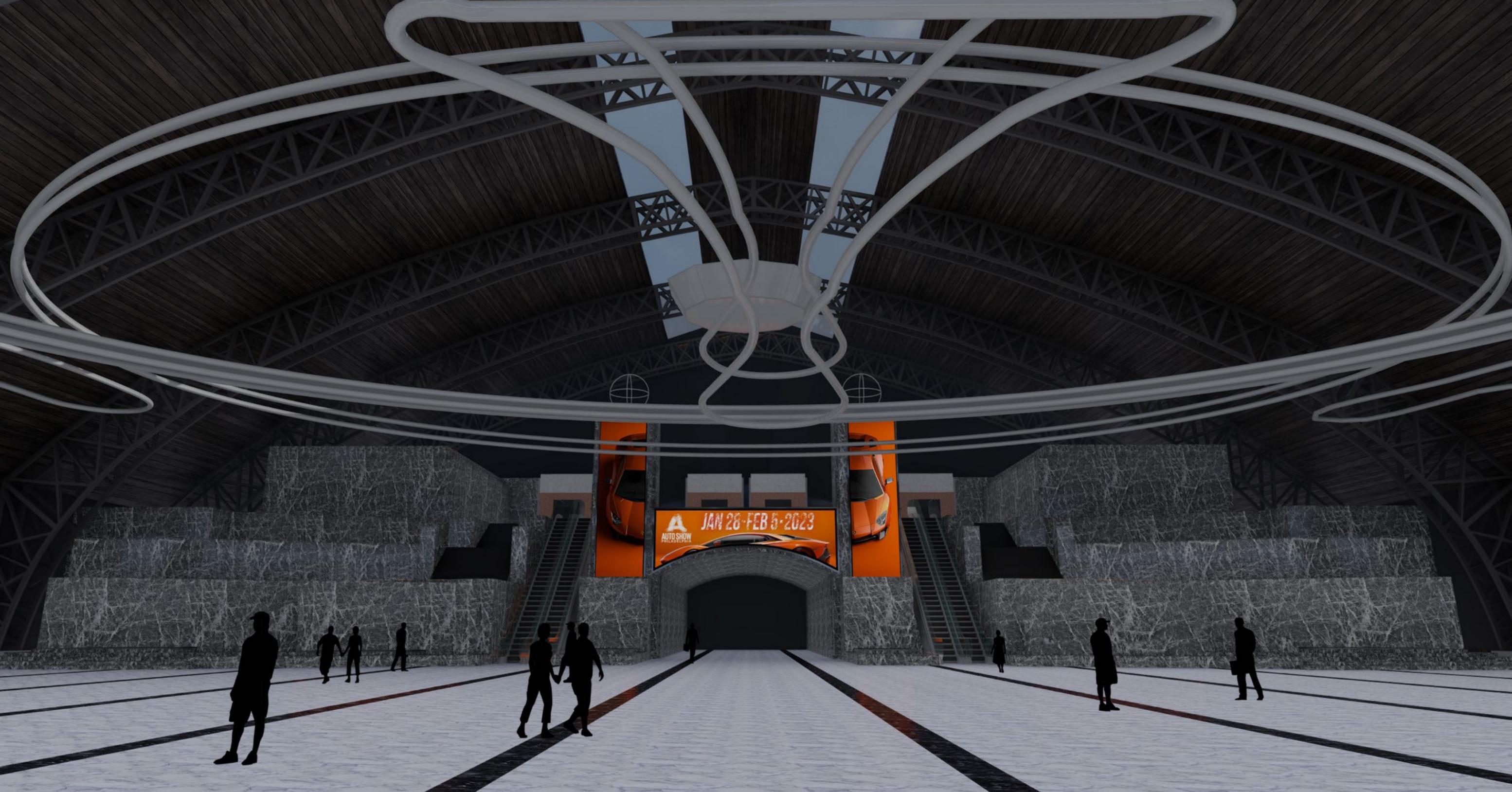

## 1.11 A-G DISPLAYS GRAND HALL WALL MOUNTED

**ANTHONY  
JAMES  
PARTNERS**

3900 WESTERRE PARKWAY, SUITE 300 804.727.0070  
RICHMOND, VIRGINIA 23233 www.anthonyjamespartners.com

\*ASSET REQUIRES FIELD SURVEY TO DETERMINE SIZING PRIOR TO FABRICATION OR INSTALLATION. DIMENSIONS NOTED IN THIS DOCUMENT ARE FOR ESTIMATION PURPOSES ONLY. VENDOR IS RESPONSIBLE FOR ANY INCONSISTENCIES BETWEEN CONCEPTS AND FIELD-VERIFIED DIMENSIONS.

THIS ARTWORK IS PROTECTED UNDER FEDERAL AND INTERNATIONAL COPYRIGHT LAW. EXPRESS PERMISSION FROM ANTHONY JAMES PARTNERS (AJP) IS REQUIRED FOR REPRODUCTION. RENDERINGS ARE FOR THE EXCLUSIVE USE OF DESIGNATED CLIENTS, ASSOCIATES AND AJP. THESE RENDERINGS DO NOT REPRESENT FABRICATION OR STRUCTURAL ENGINEER CERTIFIED OR STAMPED DOCUMENTS. MONITOR AND/OR PRINTER CALIBRATION MAY IMPAIR VISUAL ACCURACY OF SPECIFIED COLORS.

\* LED IS OUT OF 16:9 RATIO PER OWNER DIRECTION

**MUST BE FIELD VERIFIED\***

PENNSYLVANIA CONVENTION CENTER

CONCEPT RENDERING

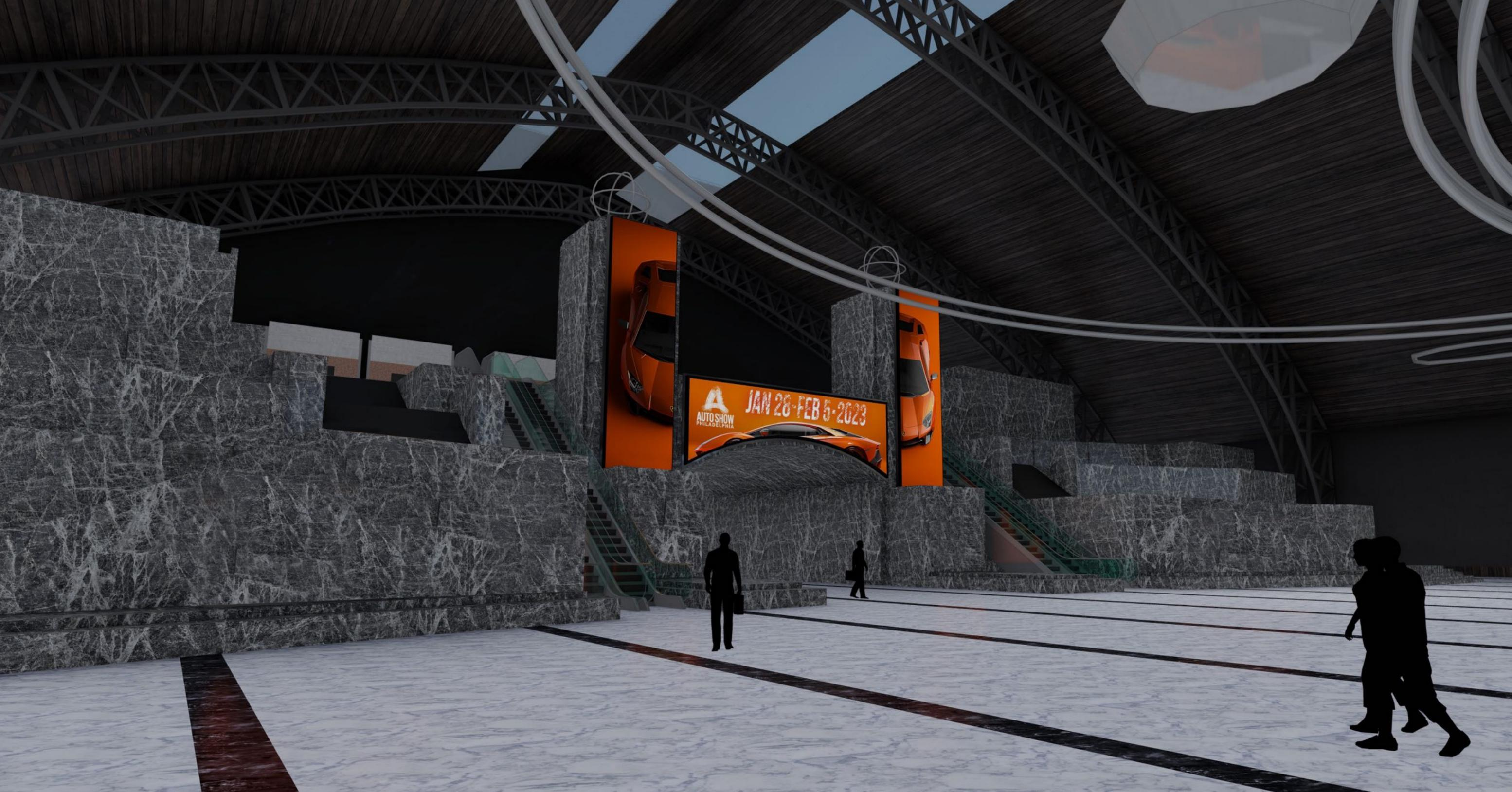

## 1.11 A-G DISPLAYS GRAND HALL WALL MOUNTED

**ANTHONY  
JAMES  
PARTNERS**

3900 WESTERRE PARKWAY, SUITE 300 804.727.0070  
RICHMOND, VIRGINIA 23233 www.anthonyjamespartners.com

\*ASSET REQUIRES FIELD SURVEY TO DETERMINE SIZING PRIOR TO FABRICATION OR INSTALLATION. DIMENSIONS NOTED IN THIS DOCUMENT ARE FOR ESTIMATION PURPOSES ONLY. VENDOR IS RESPONSIBLE FOR ANY INCONSISTENCIES BETWEEN CONCEPTS AND FIELD-VERIFIED DIMENSIONS.

THIS ARTWORK IS PROTECTED UNDER FEDERAL AND INTERNATIONAL COPYRIGHT LAW. EXPRESS PERMISSION FROM ANTHONY JAMES PARTNERS (AJP) IS REQUIRED FOR REPRODUCTION. RENDERINGS ARE FOR THE EXCLUSIVE USE OF DESIGNATED CLIENTS, ASSOCIATES AND AJP. THESE RENDERINGS DO NOT REPRESENT FABRICATION OR STRUCTURAL ENGINEER CERTIFIED OR STAMPED DOCUMENTS. MONITOR AND/OR PRINTER CALIBRATION MAY IMPAIR VISUAL ACCURACY OF SPECIFIED COLORS.

\* LED IS OUT OF 16:9 RATIO PER OWNER DIRECTION

**MUST BE FIELD VERIFIED\***

PENNSYLVANIA CONVENTION CENTER

CONCEPT RENDERING

LED DISPLAYS

\* LED WILL BE INSTALLED ON THE "NARROW". LED WILL BE ON LEGS FOR SUPPORT AND REDUCE ADDITIONAL WORK INSIDE THE SHAFT.

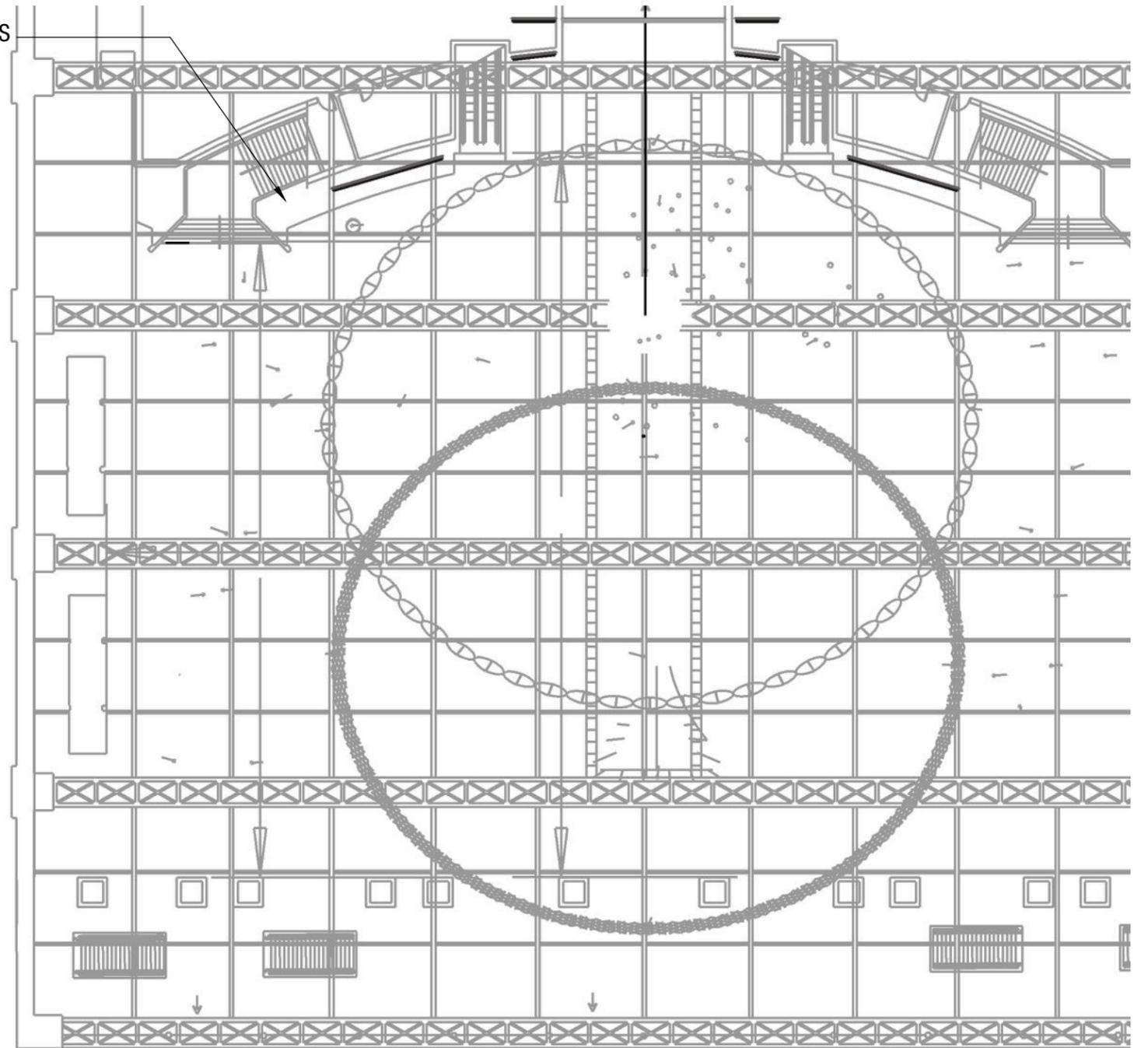
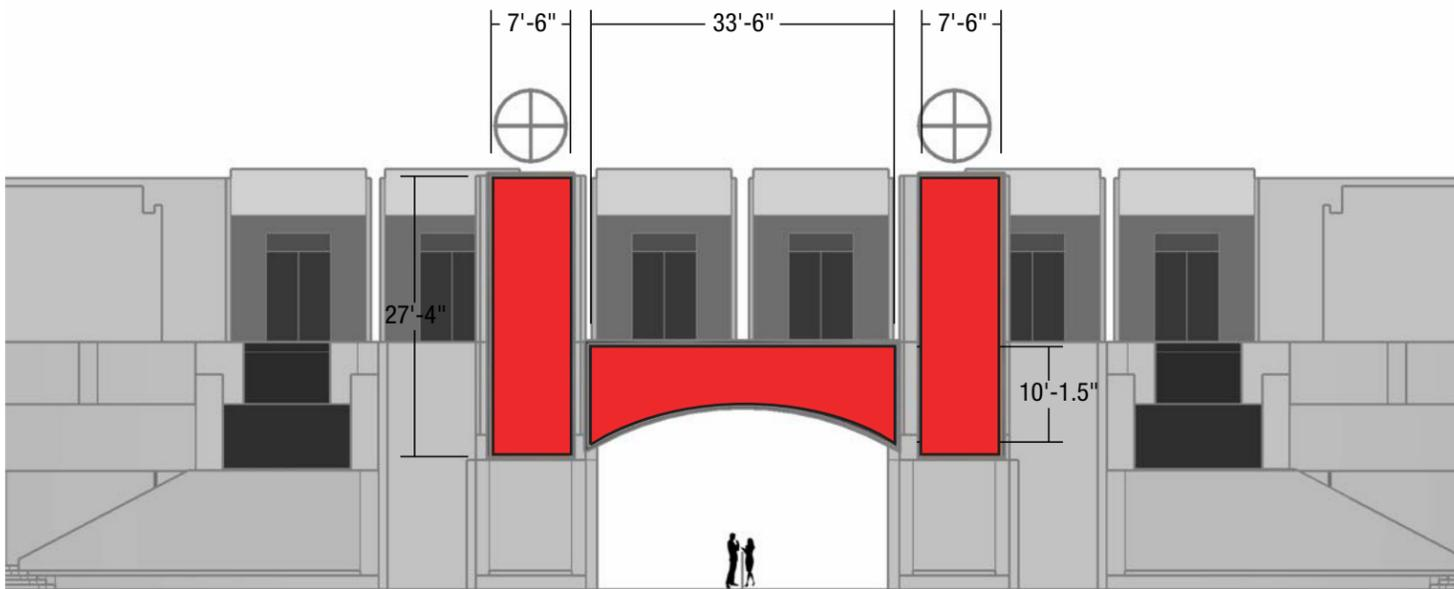

○ PLAN VIEW  
NTS

### 1.11 A-G DISPLAYS GRAND HALL WALL MOUNTED

**ANTHONY  
JAMES  
PARTNERS**

3900 WESTERRE PARKWAY, SUITE 300 804.727.0070  
RICHMOND, VIRGINIA 23233 www.anthonijamespartners.com

\*ASSET REQUIRES FIELD SURVEY TO DETERMINE SIZING PRIOR TO FABRICATION OR INSTALLATION. DIMENSIONS NOTED IN THIS DOCUMENT ARE FOR ESTIMATION PURPOSES ONLY. VENDOR IS RESPONSIBLE FOR ANY INCONSISTENCIES BETWEEN CONCEPTS AND FIELD-VERIFIED DIMENSIONS.

\* LED IS OUT OF 16:9 RATIO PER OWNER DIRECTION  
**MUST BE FIELD VERIFIED\***

PENNSYLVANIA CONVENTION CENTER

THIS ARTWORK IS PROTECTED UNDER FEDERAL AND INTERNATIONAL COPYRIGHT LAW. EXPRESS PERMISSION FROM ANTHONY JAMES PARTNERS (AJP) IS REQUIRED FOR REPRODUCTION. RENDERINGS ARE FOR THE EXCLUSIVE USE OF DESIGNATED CLIENTS, ASSOCIATES AND AJP. THESE RENDERINGS DO NOT REPRESENT FABRICATION OR STRUCTURAL ENGINEER CERTIFIED OR STAMPED DOCUMENTS. MONITOR AND/OR PRINTER CALIBRATION MAY IMPAIR VISUAL ACCURACY OF SPECIFIED COLORS.

CONCEPT RENDERING





← Box Office ATM s  
 ↖ Elevator  
 ↑ Hall F  
 11th Street Exit

↗ ATM s, Business Center  
 Gift Shop, Visitor Services  
 Halls A, B, C, D, E  
 Meeting Rooms 201-310  
 Grand Hall, Ballroom & Marriott  
 Overlook Cafe & Bar

**1.17 RIBBON STREET LEVEL 12TH AND ARCH ENTRANCE AREA EAST & WEST**

\* LED IS OUT OF 16:9 RATIO PER OWNER DIRECTION

**MUST BE FIELD VERIFIED\***

**ANTHONY  
 JAMES  
 PARTNERS**

3900 WESTERRE PARKWAY, SUITE 300 804.727.0070  
 RICHMOND, VIRGINIA 23233 www.anthonijamespartners.com

\*ASSET REQUIRES FIELD SURVEY TO DETERMINE SIZING PRIOR TO FABRICATION OR INSTALLATION. DIMENSIONS NOTED IN THIS DOCUMENT ARE FOR ESTIMATION PURPOSES ONLY. VENDOR IS RESPONSIBLE FOR ANY INCONSISTENCIES BETWEEN CONCEPTS AND FIELD-VERIFIED DIMENSIONS.

PENNSYLVANIA CONVENTION CENTER

THIS ARTWORK IS PROTECTED UNDER FEDERAL AND INTERNATIONAL COPYRIGHT LAW. EXPRESS PERMISSION FROM ANTHONY JAMES PARTNERS (AJP) IS REQUIRED FOR REPRODUCTION. RENDERINGS ARE FOR THE EXCLUSIVE USE OF DESIGNATED CLIENTS, ASSOCIATES AND AJP. THESE RENDERINGS DO NOT REPRESENT FABRICATION OR STRUCTURAL ENGINEER CERTIFIED OR STAMPED DOCUMENTS. MONITOR AND/OR PRINTER CALIBRATION MAY IMPAIR VISUAL ACCURACY OF SPECIFIED COLORS.

CONCEPT RENDERING

DECORATIVE OVERSIZED  
BACKER PANEL  
MATERIAL TBD.

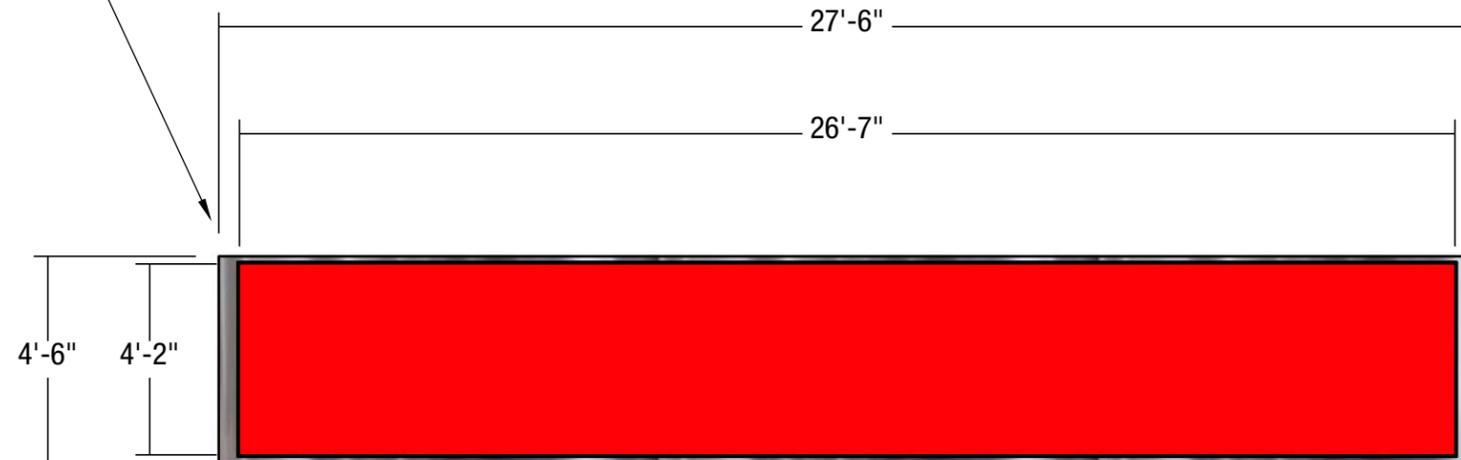

○ LED LAYOUT  
1/4" = 1'-0"

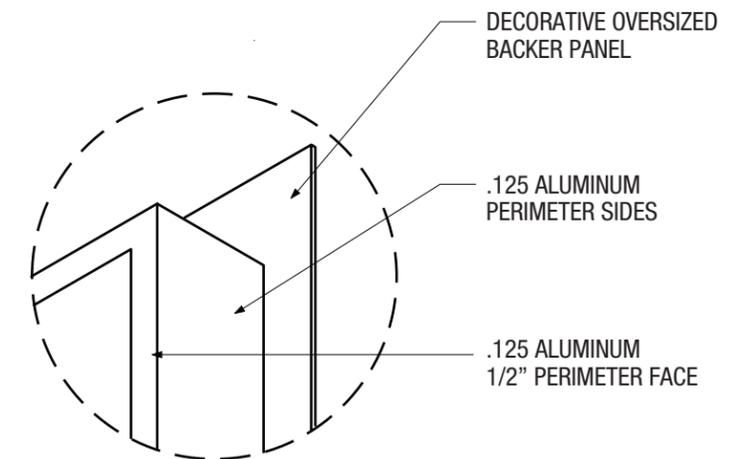

○ LED DETAIL (SURROUND)  
NTS

### 1.17 RIBBON STREET LEVEL 12TH AND ARCH ENTRANCE AREA EAST & WEST

\* LED IS OUT OF 16:9 RATIO PER OWNER DIRECTION

**MUST BE FIELD VERIFIED\***

**ANTHONY  
JAMES  
PARTNERS**

3900 WESTERRE PARKWAY, SUITE 300 804.727.0070  
RICHMOND, VIRGINIA 23233 www.anthonyjamespartners.com

\*ASSET REQUIRES FIELD SURVEY TO DETERMINE SIZING PRIOR TO FABRICATION OR INSTALLATION. DIMENSIONS NOTED IN THIS DOCUMENT ARE FOR ESTIMATION PURPOSES ONLY. VENDOR IS RESPONSIBLE FOR ANY INCONSISTENCIES BETWEEN CONCEPTS AND FIELD-VERIFIED DIMENSIONS.

PENNSYLVANIA CONVENTION CENTER

THIS ARTWORK IS PROTECTED UNDER FEDERAL AND INTERNATIONAL COPYRIGHT LAW. EXPRESS PERMISSION FROM ANTHONY JAMES PARTNERS (AJP) IS REQUIRED FOR REPRODUCTION. RENDERINGS ARE FOR THE EXCLUSIVE USE OF DESIGNATED CLIENTS, ASSOCIATES AND AJP. THESE RENDERINGS DO NOT REPRESENT FABRICATION OR STRUCTURAL ENGINEER CERTIFIED OR STAMPED DOCUMENTS. MONITOR AND/OR PRINTER CALIBRATION MAY IMPAIR VISUAL ACCURACY OF SPECIFIED COLORS.

CONCEPT RENDERING



**1.18A RIBBON 200 LEVEL NORTH FROM GRAND HALL**

**ANTHONY  
JAMES  
PARTNERS**

3900 WESTERRE PARKWAY, SUITE 300 804.727.0070  
RICHMOND, VIRGINIA 23233 www.anthonyjamespartners.com

\*ASSET REQUIRES FIELD SURVEY TO DETERMINE SIZING PRIOR TO FABRICATION OR INSTALLATION. DIMENSIONS NOTED IN THIS DOCUMENT ARE FOR ESTIMATION PURPOSES ONLY. VENDOR IS RESPONSIBLE FOR ANY INCONSISTENCIES BETWEEN CONCEPTS AND FIELD-VERIFIED DIMENSIONS.

THIS ARTWORK IS PROTECTED UNDER FEDERAL AND INTERNATIONAL COPYRIGHT LAW. EXPRESS PERMISSION FROM ANTHONY JAMES PARTNERS (AJP) IS REQUIRED FOR REPRODUCTION. RENDERINGS ARE FOR THE EXCLUSIVE USE OF DESIGNATED CLIENTS, ASSOCIATES AND AJP. THESE RENDERINGS DO NOT REPRESENT FABRICATION OR STRUCTURAL ENGINEER CERTIFIED OR STAMPED DOCUMENTS. MONITOR AND/OR PRINTER CALIBRATION MAY IMPAIR VISUAL ACCURACY OF SPECIFIED COLORS.

\* LED IS OUT OF 16:9 RATIO PER OWNER DIRECTION

**MUST BE FIELD VERIFIED\***

PENNSYLVANIA CONVENTION CENTER

CONCEPT RENDERING

DECORATIVE OVERSIZED  
BACKER PANEL  
MATERIAL TBD.

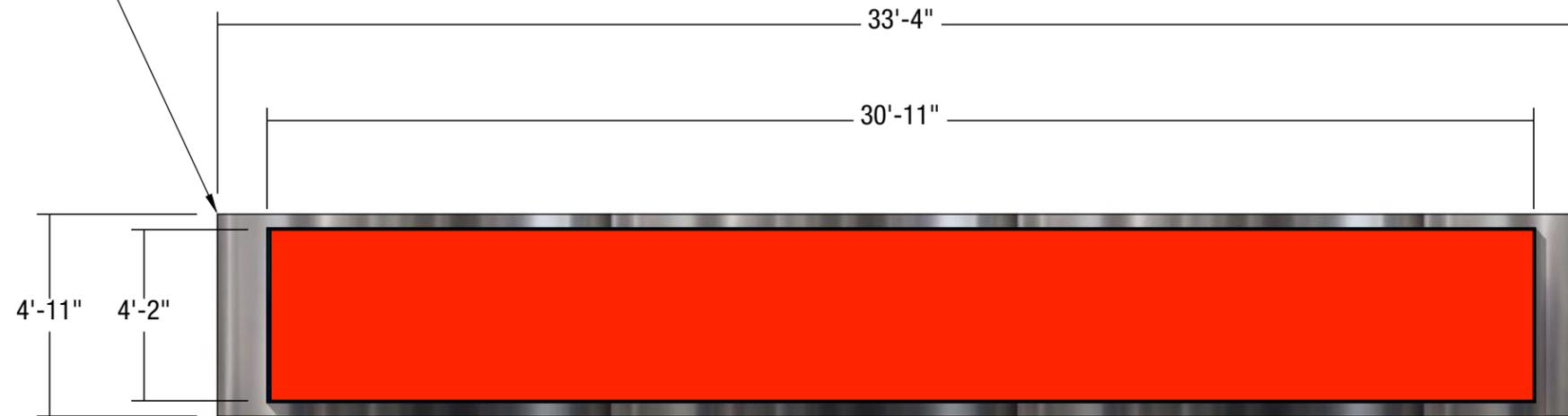

○ LED LAYOUT  
1/4" = 1'-0"

\* RELOCATION OF HVAC VENTS  
& FIRE ALARMS SHALL BE INCLUDED.  
ANY WALL REPAIR & PAINTING  
REQUIRED FROM RELOCATIONS SHALL  
ALSO BE INCLUDED.

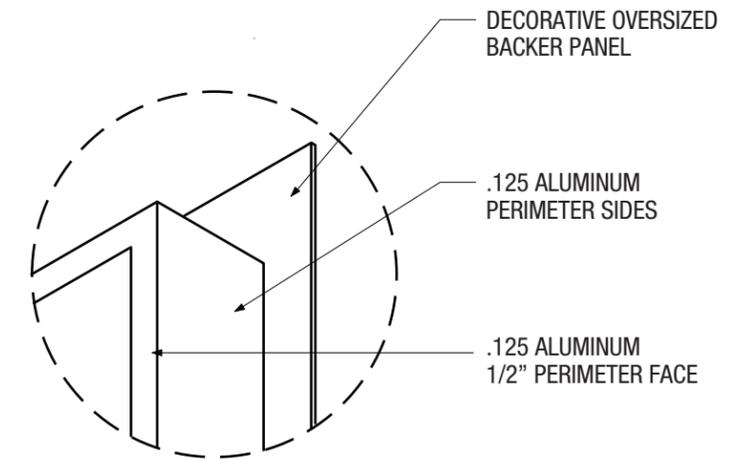

○ LED DETAIL (SURROUND)  
NTS

\* LED IS OUT OF 16:9 RATIO PER OWNER DIRECTION  
**MUST BE FIELD VERIFIED\***

**1.18A RIBBON 200 LEVEL NORTH FROM GRAND HALL**

**ANTHONY  
JAMES  
PARTNERS**

3900 WESTERRE PARKWAY, SUITE 300 804.727.0070  
RICHMOND, VIRGINIA 23233 www.anthonyjamespartners.com

\*ASSET REQUIRES FIELD SURVEY TO DETERMINE SIZING PRIOR TO FABRICATION OR INSTALLATION. DIMENSIONS NOTED IN THIS DOCUMENT ARE FOR ESTIMATION PURPOSES ONLY. VENDOR IS RESPONSIBLE FOR ANY INCONSISTENCIES BETWEEN CONCEPTS AND FIELD-VERIFIED DIMENSIONS.

PENNSYLVANIA CONVENTION CENTER

THIS ARTWORK IS PROTECTED UNDER FEDERAL AND INTERNATIONAL COPYRIGHT LAW. EXPRESS PERMISSION FROM ANTHONY JAMES PARTNERS (AJP) IS REQUIRED FOR REPRODUCTION. RENDERINGS ARE FOR THE EXCLUSIVE USE OF DESIGNATED CLIENTS, ASSOCIATES AND AJP. THESE RENDERINGS DO NOT REPRESENT FABRICATION OR STRUCTURAL ENGINEER CERTIFIED OR STAMPED DOCUMENTS. MONITOR AND/OR PRINTER CALIBRATION MAY IMPAIR VISUAL ACCURACY OF SPECIFIED COLORS.

CONCEPT RENDERING



**1.18B RIBBON 200 LEVEL NORTH FROM GRAND HALL**

**ANTHONY  
JAMES  
PARTNERS**

3900 WESTERRE PARKWAY, SUITE 300 804.727.0070  
RICHMOND, VIRGINIA 23233 www.anthonyjamespartners.com

\*ASSET REQUIRES FIELD SURVEY TO DETERMINE SIZING PRIOR TO FABRICATION OR INSTALLATION. DIMENSIONS NOTED IN THIS DOCUMENT ARE FOR ESTIMATION PURPOSES ONLY. VENDOR IS RESPONSIBLE FOR ANY INCONSISTENCIES BETWEEN CONCEPTS AND FIELD-VERIFIED DIMENSIONS.

THIS ARTWORK IS PROTECTED UNDER FEDERAL AND INTERNATIONAL COPYRIGHT LAW. EXPRESS PERMISSION FROM ANTHONY JAMES PARTNERS (AJP) IS REQUIRED FOR REPRODUCTION. RENDERINGS ARE FOR THE EXCLUSIVE USE OF DESIGNATED CLIENTS, ASSOCIATES AND AJP. THESE RENDERINGS DO NOT REPRESENT FABRICATION OR STRUCTURAL ENGINEER CERTIFIED OR STAMPED DOCUMENTS. MONITOR AND/OR PRINTER CALIBRATION MAY IMPAIR VISUAL ACCURACY OF SPECIFIED COLORS.

\* LED IS OUT OF 16:9 RATIO PER OWNER DIRECTION

**MUST BE FIELD VERIFIED\***

PENNSYLVANIA CONVENTION CENTER

CONCEPT RENDERING

DECORATIVE OVERSIZED  
BACKER PANEL  
MATERIAL TBD.

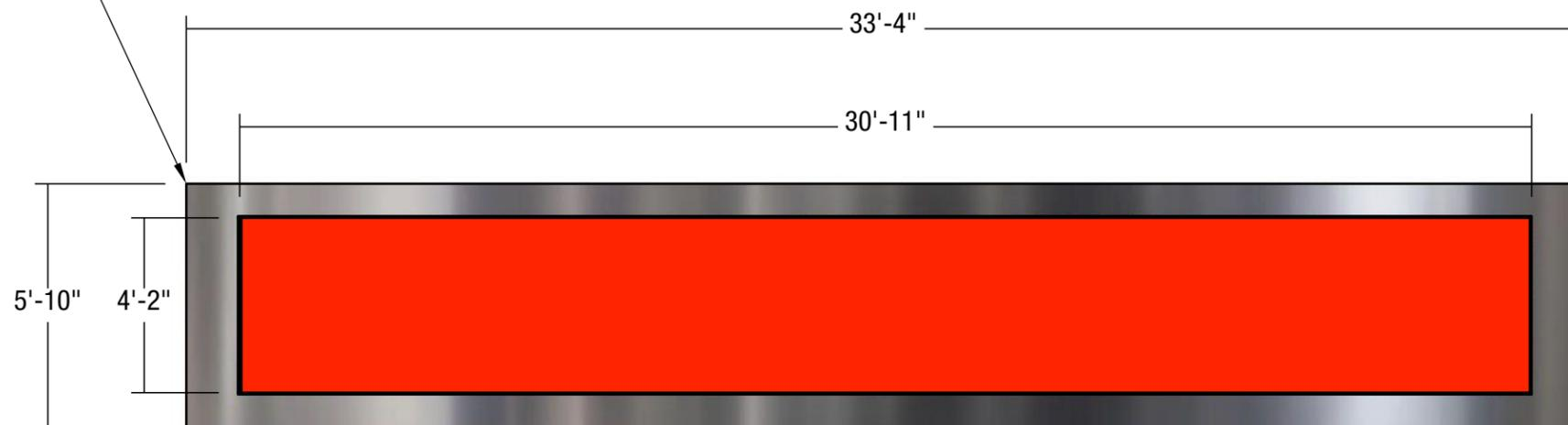

○ LED LAYOUT  
1/4" = 1'-0"

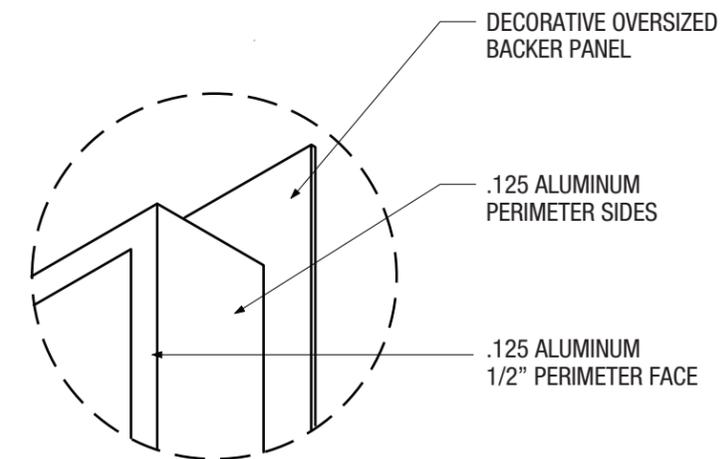

○ LED DETAIL (SURROUND)  
NTS

**1.18B RIBBON 200 LEVEL NORTH FROM GRAND HALL**

\* LED IS OUT OF 16:9 RATIO PER OWNER DIRECTION  
**MUST BE FIELD VERIFIED\***

**ANTHONY  
JAMES  
PARTNERS**

3900 WESTERRE PARKWAY, SUITE 300 804.727.0070  
RICHMOND, VIRGINIA 23233 www.anthonyjamespartners.com

\*ASSET REQUIRES FIELD SURVEY TO DETERMINE SIZING PRIOR TO FABRICATION OR INSTALLATION. DIMENSIONS NOTED IN THIS DOCUMENT ARE FOR ESTIMATION PURPOSES ONLY. VENDOR IS RESPONSIBLE FOR ANY INCONSISTENCIES BETWEEN CONCEPTS AND FIELD-VERIFIED DIMENSIONS.

PENNSYLVANIA CONVENTION CENTER

THIS ARTWORK IS PROTECTED UNDER FEDERAL AND INTERNATIONAL COPYRIGHT LAW. EXPRESS PERMISSION FROM ANTHONY JAMES PARTNERS (AJP) IS REQUIRED FOR REPRODUCTION. RENDERINGS ARE FOR THE EXCLUSIVE USE OF DESIGNATED CLIENTS, ASSOCIATES AND AJP. THESE RENDERINGS DO NOT REPRESENT FABRICATION OR STRUCTURAL ENGINEER CERTIFIED OR STAMPED DOCUMENTS. MONITOR AND/OR PRINTER CALIBRATION MAY IMPAIR VISUAL ACCURACY OF SPECIFIED COLORS.

CONCEPT RENDERING



**1.19 CURVED RIBBON 200 LEVEL EAST TOWARD CROSSROADS**

**ANTHONY  
JAMES  
PARTNERS**

3900 WESTERRE PARKWAY, SUITE 300 804.727.0070  
 RICHMOND, VIRGINIA 23233 www.anthonijamespartners.com

\*ASSET REQUIRES FIELD SURVEY TO DETERMINE SIZING PRIOR TO FABRICATION OR INSTALLATION. DIMENSIONS NOTED IN THIS DOCUMENT ARE FOR ESTIMATION PURPOSES ONLY. VENDOR IS RESPONSIBLE FOR ANY INCONSISTENCIES BETWEEN CONCEPTS AND FIELD-VERIFIED DIMENSIONS.

THIS ARTWORK IS PROTECTED UNDER FEDERAL AND INTERNATIONAL COPYRIGHT LAW. EXPRESS PERMISSION FROM ANTHONY JAMES PARTNERS (AJP) IS REQUIRED FOR REPRODUCTION. RENDERINGS ARE FOR THE EXCLUSIVE USE OF DESIGNATED CLIENTS, ASSOCIATES AND AJP. THESE RENDERINGS DO NOT REPRESENT FABRICATION OR STRUCTURAL ENGINEER CERTIFIED OR STAMPED DOCUMENTS. MONITOR AND/OR PRINTER CALIBRATION MAY IMPAIR VISUAL ACCURACY OF SPECIFIED COLORS.

\* LED IS OUT OF 16:9 RATIO PER OWNER DIRECTION

**MUST BE FIELD VERIFIED\***

PENNSYLVANIA CONVENTION CENTER

CONCEPT RENDERING

DECORATIVE OVERSIZED  
BACKER PANEL  
MATERIAL TBD.



○ LED LAYOUT  
1/4" = 1'-0"

CURVED DISPLAY.  
R. 20'-0"

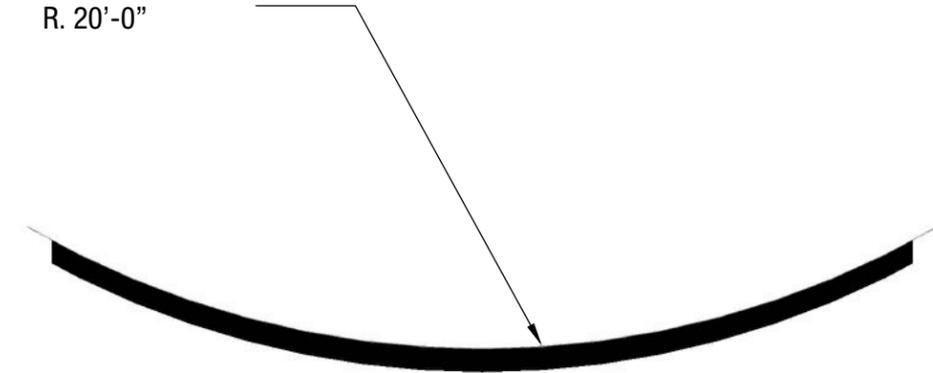

○ LED PLAN  
1/4" = 1'-0"

\* RELOCATION OF HVAC VENTS  
& FIRE ALARMS SHALL BE INCLUDED.  
ANY WALL REPAIR & PAINTING  
REQUIRED FROM RELOCATIONS SHALL  
ALSO BE INCLUDED.

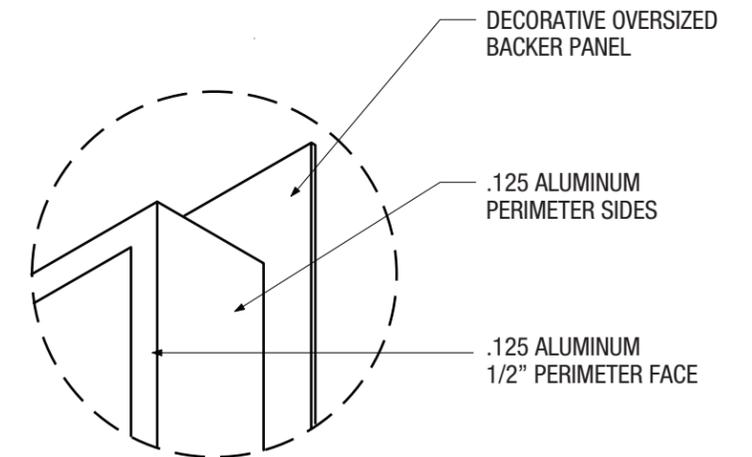

○ LED DETAIL (SURROUND)  
NTS

\* LED IS OUT OF 16:9 RATIO PER OWNER DIRECTION  
**MUST BE FIELD VERIFIED\***

### 1.19 CURVED RIBBON 200 LEVEL EAST TOWARD CROSSROADS

**ANTHONY  
JAMES  
PARTNERS**

3900 WESTERRE PARKWAY, SUITE 300 804.727.0070  
RICHMOND, VIRGINIA 23233 www.anthonyjamespartners.com

\*ASSET REQUIRES FIELD SURVEY TO DETERMINE SIZING PRIOR TO FABRICATION OR INSTALLATION. DIMENSIONS NOTED IN THIS DOCUMENT ARE FOR ESTIMATION PURPOSES ONLY. VENDOR IS RESPONSIBLE FOR ANY INCONSISTENCIES BETWEEN CONCEPTS AND FIELD-VERIFIED DIMENSIONS.

PENNSYLVANIA CONVENTION CENTER

THIS ARTWORK IS PROTECTED UNDER FEDERAL AND INTERNATIONAL COPYRIGHT LAW. EXPRESS PERMISSION FROM ANTHONY JAMES PARTNERS (AJP) IS REQUIRED FOR REPRODUCTION. RENDERINGS ARE FOR THE EXCLUSIVE USE OF DESIGNATED CLIENTS, ASSOCIATES AND AJP. THESE RENDERINGS DO NOT REPRESENT FABRICATION OR STRUCTURAL ENGINEER CERTIFIED OR STAMPED DOCUMENTS. MONITOR AND/OR PRINTER CALIBRATION MAY IMPAIR VISUAL ACCURACY OF SPECIFIED COLORS.

CONCEPT RENDERING





## 1.20 CURVED RIBBON 200 LEVEL OVERLOOK CAFE

**ANTHONY  
JAMES  
PARTNERS**

3900 WESTERRE PARKWAY, SUITE 300 804.727.0070  
RICHMOND, VIRGINIA 23233 www.anthonyjamespartners.com

\*ASSET REQUIRES FIELD SURVEY TO DETERMINE SIZING PRIOR TO FABRICATION OR INSTALLATION. DIMENSIONS NOTED IN THIS DOCUMENT ARE FOR ESTIMATION PURPOSES ONLY. VENDOR IS RESPONSIBLE FOR ANY INCONSISTENCIES BETWEEN CONCEPTS AND FIELD-VERIFIED DIMENSIONS.

THIS ARTWORK IS PROTECTED UNDER FEDERAL AND INTERNATIONAL COPYRIGHT LAW. EXPRESS PERMISSION FROM ANTHONY JAMES PARTNERS (AJP) IS REQUIRED FOR REPRODUCTION. RENDERINGS ARE FOR THE EXCLUSIVE USE OF DESIGNATED CLIENTS, ASSOCIATES AND AJP. THESE RENDERINGS DO NOT REPRESENT FABRICATION OR STRUCTURAL ENGINEER CERTIFIED OR STAMPED DOCUMENTS. MONITOR AND/OR PRINTER CALIBRATION MAY IMPAIR VISUAL ACCURACY OF SPECIFIED COLORS.

\* LED IS OUT OF 16:9 RATIO PER OWNER DIRECTION

**MUST BE FIELD VERIFIED\***

PENNSYLVANIA CONVENTION CENTER

CONCEPT RENDERING

DECORATIVE OVERSIZED  
BACKER PANEL  
MATERIAL TBD.



LED LAYOUT  
1/4" = 1'-0"

CURVED DISPLAY.  
R. 32'-0"



LED PLAN  
1/4" = 1'-0"

\* RELOCATION OF HVAC VENTS  
& FIRE ALARMS SHALL BE INCLUDED.  
ANY WALL REPAIR & PAINTING  
REQUIRED FROM RELOCATIONS SHALL  
ALSO BE INCLUDED.

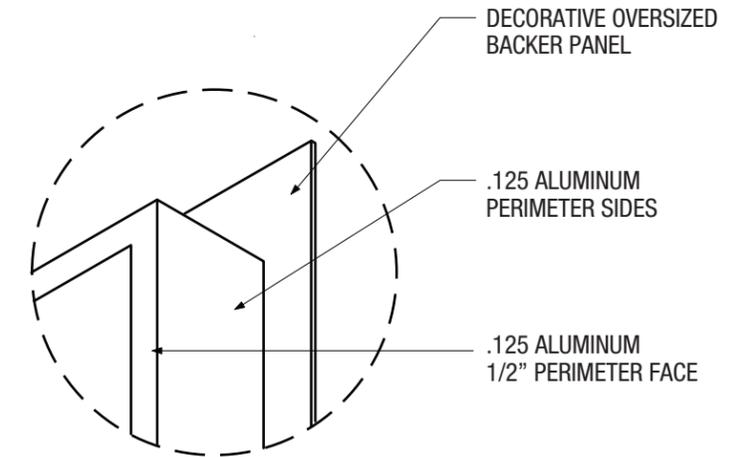

LED DETAIL (SURROUND)  
NTS

\* LED IS OUT OF 16:9 RATIO PER OWNER DIRECTION  
**MUST BE FIELD VERIFIED\***

**1.20 CURVED RIBBON 200 LEVEL OVERLOOK CAFE**

**ANTHONY  
JAMES  
PARTNERS**

3900 WESTERRE PARKWAY, SUITE 300 804.727.0070  
RICHMOND, VIRGINIA 23233 www.anthonyjamespartners.com

\*ASSET REQUIRES FIELD SURVEY TO DETERMINE SIZING PRIOR TO FABRICATION OR INSTALLATION. DIMENSIONS NOTED IN THIS DOCUMENT ARE FOR ESTIMATION PURPOSES ONLY. VENDOR IS RESPONSIBLE FOR ANY INCONSISTENCIES BETWEEN CONCEPTS AND FIELD-VERIFIED DIMENSIONS.

PENNSYLVANIA CONVENTION CENTER

THIS ARTWORK IS PROTECTED UNDER FEDERAL AND INTERNATIONAL COPYRIGHT LAW. EXPRESS PERMISSION FROM ANTHONY JAMES PARTNERS (AJP) IS REQUIRED FOR REPRODUCTION. RENDERINGS ARE FOR THE EXCLUSIVE USE OF DESIGNATED CLIENTS, ASSOCIATES AND AJP. THESE RENDERINGS DO NOT REPRESENT FABRICATION OR STRUCTURAL ENGINEER CERTIFIED OR STAMPED DOCUMENTS. MONITOR AND/OR PRINTER CALIBRATION MAY IMPAIR VISUAL ACCURACY OF SPECIFIED COLORS.

CONCEPT RENDERING



**1.22 RIBBON 200 LEVEL HALL C**

**ANTHONY  
JAMES  
PARTNERS**

3900 WESTERRE PARKWAY, SUITE 300  
RICHMOND, VIRGINIA 23233

804.727.0070  
www.anthonijamespartners.com

\*ASSET REQUIRES FIELD SURVEY TO DETERMINE SIZING PRIOR TO FABRICATION OR INSTALLATION. DIMENSIONS NOTED IN THIS DOCUMENT ARE FOR ESTIMATION PURPOSES ONLY. VENDOR IS RESPONSIBLE FOR ANY INCONSISTENCIES BETWEEN CONCEPTS AND FIELD-VERIFIED DIMENSIONS.

THIS ARTWORK IS PROTECTED UNDER FEDERAL AND INTERNATIONAL COPYRIGHT LAW. EXPRESS PERMISSION FROM ANTHONY JAMES PARTNERS (AJP) IS REQUIRED FOR REPRODUCTION. RENDERINGS ARE FOR THE EXCLUSIVE USE OF DESIGNATED CLIENTS, ASSOCIATES AND AJP. THESE RENDERINGS DO NOT REPRESENT FABRICATION OR STRUCTURAL ENGINEER CERTIFIED OR STAMPED DOCUMENTS. MONITOR AND/OR PRINTER CALIBRATION MAY IMPAIR VISUAL ACCURACY OF SPECIFIED COLORS.

\* LED IS OUT OF 16:9 RATIO PER OWNER DIRECTION

**MUST BE FIELD VERIFIED\***

PENNSYLVANIA CONVENTION CENTER

CONCEPT RENDERING

DECORATIVE OVERSIZED  
BACKER PANEL  
MATERIAL TBD.



○ LED LAYOUT  
1/4" = 1'-0"

\* RELOCATION OF HVAC VENTS  
& FIRE ALARMS SHALL BE INCLUDED.  
ANY WALL REPAIR & PAINTING  
REQUIRED FROM RELOCATIONS SHALL  
ALSO BE INCLUDED.

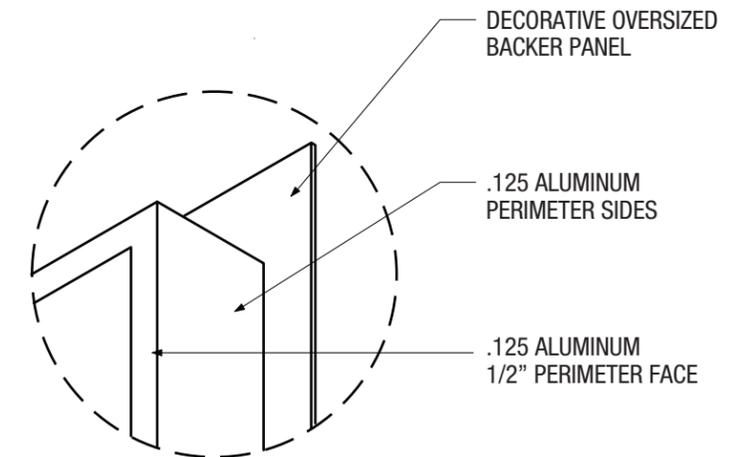

○ LED DETAIL (SURROUND)  
NTS

\* LED IS OUT OF 16:9 RATIO PER OWNER DIRECTION  
**MUST BE FIELD VERIFIED\***

## 1.22 RIBBON 200 LEVEL HALL C

**ANTHONY  
JAMES  
PARTNERS**

3900 WESTERRE PARKWAY, SUITE 300 804.727.0070  
RICHMOND, VIRGINIA 23233 www.anthonijamespartners.com

\*ASSET REQUIRES FIELD SURVEY TO DETERMINE SIZING PRIOR TO FABRICATION OR INSTALLATION. DIMENSIONS NOTED IN THIS DOCUMENT ARE FOR ESTIMATION PURPOSES ONLY. VENDOR IS RESPONSIBLE FOR ANY INCONSISTENCIES BETWEEN CONCEPTS AND FIELD-VERIFIED DIMENSIONS.

PENNSYLVANIA CONVENTION CENTER

THIS ARTWORK IS PROTECTED UNDER FEDERAL AND INTERNATIONAL COPYRIGHT LAW. EXPRESS PERMISSION FROM ANTHONY JAMES PARTNERS (AJP) IS REQUIRED FOR REPRODUCTION. RENDERINGS ARE FOR THE EXCLUSIVE USE OF DESIGNATED CLIENTS, ASSOCIATES AND AJP. THESE RENDERINGS DO NOT REPRESENT FABRICATION OR STRUCTURAL ENGINEER CERTIFIED OR STAMPED DOCUMENTS. MONITOR AND/OR PRINTER CALIBRATION MAY IMPAIR VISUAL ACCURACY OF SPECIFIED COLORS.

CONCEPT RENDERING



### 3.4 MONITOR 55" WAYFINDING OVERHEAD DOUBLE-SIDED LCD

**ANTHONY  
JAMES  
PARTNERS**

3900 WESTERRE PARKWAY, SUITE 300 804.727.0070  
RICHMOND, VIRGINIA 23233 www.anthonyjamespartners.com

\*ASSET REQUIRES FIELD SURVEY TO DETERMINE SIZING PRIOR TO FABRICATION OR INSTALLATION. DIMENSIONS NOTED IN THIS DOCUMENT ARE FOR ESTIMATION PURPOSES ONLY. VENDOR IS RESPONSIBLE FOR ANY INCONSISTENCIES BETWEEN CONCEPTS AND FIELD-VERIFIED DIMENSIONS.

THIS ARTWORK IS PROTECTED UNDER FEDERAL AND INTERNATIONAL COPYRIGHT LAW. EXPRESS PERMISSION FROM ANTHONY JAMES PARTNERS (AJP) IS REQUIRED FOR REPRODUCTION. RENDERINGS ARE FOR THE EXCLUSIVE USE OF DESIGNATED CLIENTS, ASSOCIATES AND AJP. THESE RENDERINGS DO NOT REPRESENT FABRICATION OR STRUCTURAL ENGINEER CERTIFIED OR STAMPED DOCUMENTS. MONITOR AND/OR PRINTER CALIBRATION MAY IMPAIR VISUAL ACCURACY OF SPECIFIED COLORS.

**MUST BE FIELD VERIFIED\***

PENNSYLVANIA CONVENTION CENTER

CONCEPT RENDERING

DECORATIVE OVERSIZED  
BACKER PANEL  
MATERIAL TBD.

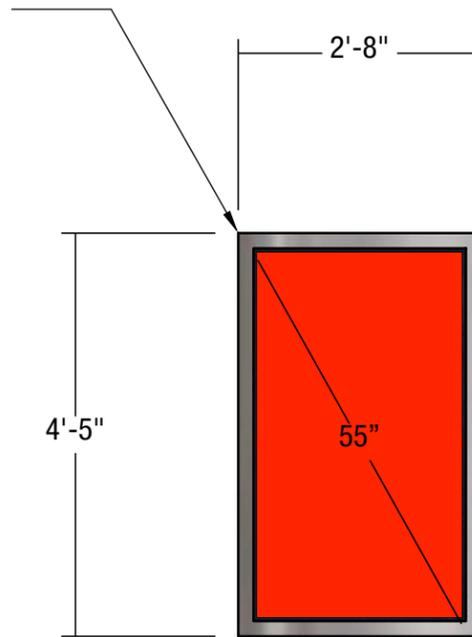

○ LCD LAYOUT  
3/8" = 1'-0"



○ LCD PROFILE  
3/8" = 1'-0"

### 3.4 MONITOR 55" WAYFINDING OVERHEAD DOUBLE-SIDED LCD

\* LED IS OUT OF 16:9 RATIO PER OWNER DIRECTION

**MUST BE FIELD VERIFIED\***

**ANTHONY  
JAMES  
PARTNERS**

3900 WESTERRE PARKWAY, SUITE 300 804.727.0070  
RICHMOND, VIRGINIA 23233 www.anthonyjamespartners.com

\*ASSET REQUIRES FIELD SURVEY TO DETERMINE SIZING PRIOR TO FABRICATION OR INSTALLATION. DIMENSIONS NOTED IN THIS DOCUMENT ARE FOR ESTIMATION PURPOSES ONLY. VENDOR IS RESPONSIBLE FOR ANY INCONSISTENCIES BETWEEN CONCEPTS AND FIELD-VERIFIED DIMENSIONS.

PENNSYLVANIA CONVENTION CENTER

THIS ARTWORK IS PROTECTED UNDER FEDERAL AND INTERNATIONAL COPYRIGHT LAW. EXPRESS PERMISSION FROM ANTHONY JAMES PARTNERS (AJP) IS REQUIRED FOR REPRODUCTION. RENDERINGS ARE FOR THE EXCLUSIVE USE OF DESIGNATED CLIENTS, ASSOCIATES AND AJP. THESE RENDERINGS DO NOT REPRESENT FABRICATION OR STRUCTURAL ENGINEER CERTIFIED OR STAMPED DOCUMENTS. MONITOR AND/OR PRINTER CALIBRATION MAY IMPAIR VISUAL ACCURACY OF SPECIFIED COLORS.

CONCEPT RENDERING



### 3.5 MONITOR 65" WALL MOUNT

**ANTHONY  
JAMES  
PARTNERS**

3900 WESTERRE PARKWAY, SUITE 300 RICHMOND, VIRGINIA 23233 804.727.0070  
www.anthonijamespartners.com

\*ASSET REQUIRES FIELD SURVEY TO DETERMINE SIZING PRIOR TO FABRICATION OR INSTALLATION. DIMENSIONS NOTED IN THIS DOCUMENT ARE FOR ESTIMATION PURPOSES ONLY. VENDOR IS RESPONSIBLE FOR ANY INCONSISTENCIES BETWEEN CONCEPTS AND FIELD-VERIFIED DIMENSIONS.

THIS ARTWORK IS PROTECTED UNDER FEDERAL AND INTERNATIONAL COPYRIGHT LAW. EXPRESS PERMISSION FROM ANTHONY JAMES PARTNERS (AJP) IS REQUIRED FOR REPRODUCTION. RENDERINGS ARE FOR THE EXCLUSIVE USE OF DESIGNATED CLIENTS, ASSOCIATES AND AJP. THESE RENDERINGS DO NOT REPRESENT FABRICATION OR STRUCTURAL ENGINEER CERTIFIED OR STAMPED DOCUMENTS. MONITOR AND/OR PRINTER CALIBRATION MAY IMPAIR VISUAL ACCURACY OF SPECIFIED COLORS.

**MUST BE FIELD VERIFIED\***

PENNSYLVANIA CONVENTION CENTER

CONCEPT RENDERING

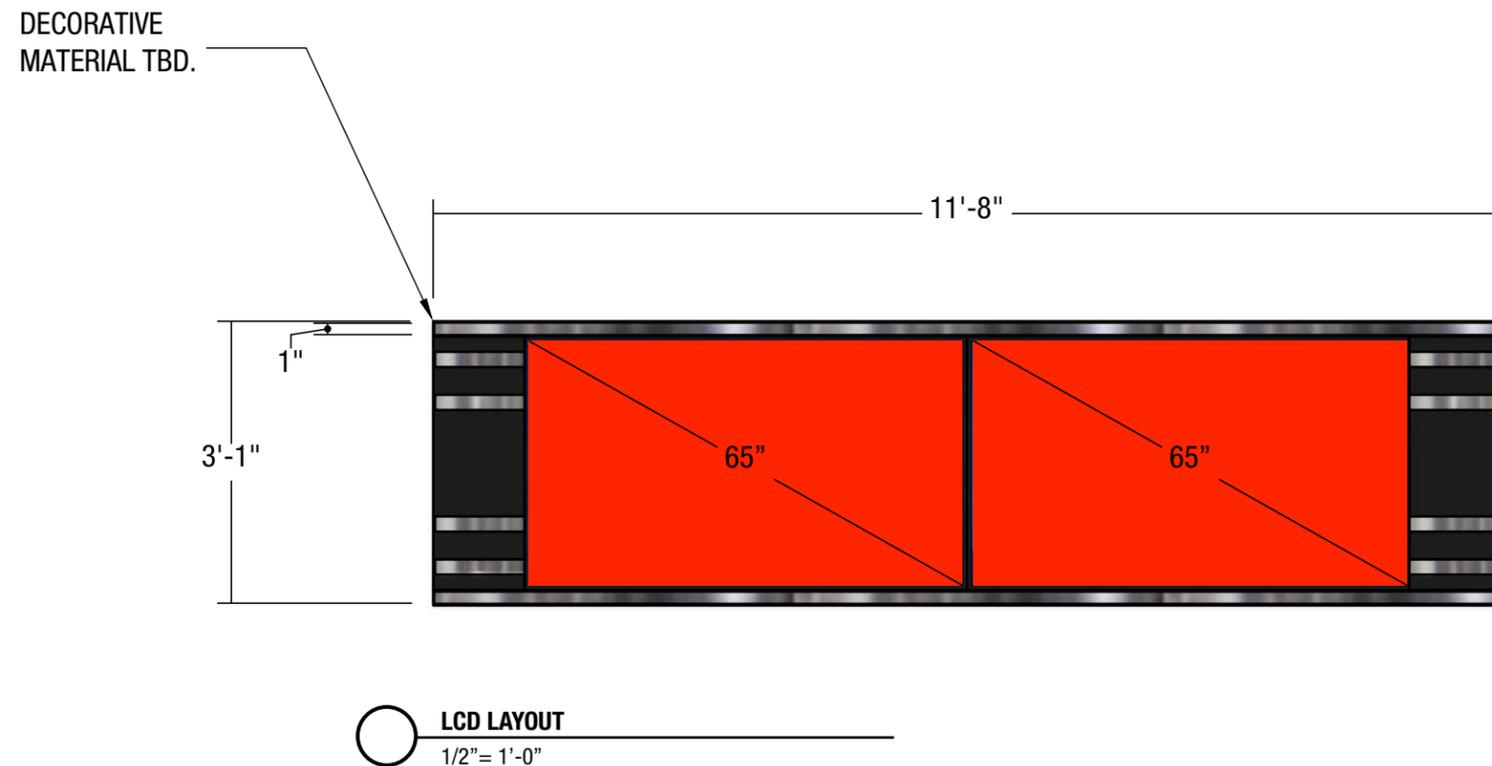

### 3.5 MONITOR 65" WALL MOUNT

**ANTHONY  
JAMES  
PARTNERS**

3900 WESTERRE PARKWAY, SUITE 300 RICHMOND, VIRGINIA 23233 804.727.0070  
www.anthonijamespartners.com

\*ASSET REQUIRES FIELD SURVEY TO DETERMINE SIZING PRIOR TO FABRICATION OR INSTALLATION. DIMENSIONS NOTED IN THIS DOCUMENT ARE FOR ESTIMATION PURPOSES ONLY. VENDOR IS RESPONSIBLE FOR ANY INCONSISTENCIES BETWEEN CONCEPTS AND FIELD-VERIFIED DIMENSIONS.

\* LED IS OUT OF 16:9 RATIO PER OWNER DIRECTION

**MUST BE FIELD VERIFIED\***

PENNSYLVANIA CONVENTION CENTER

THIS ARTWORK IS PROTECTED UNDER FEDERAL AND INTERNATIONAL COPYRIGHT LAW. EXPRESS PERMISSION FROM ANTHONY JAMES PARTNERS (AJP) IS REQUIRED FOR REPRODUCTION. RENDERINGS ARE FOR THE EXCLUSIVE USE OF DESIGNATED CLIENTS, ASSOCIATES AND AJP. THESE RENDERINGS DO NOT REPRESENT FABRICATION OR STRUCTURAL ENGINEER CERTIFIED OR STAMPED DOCUMENTS. MONITOR AND/OR PRINTER CALIBRATION MAY IMPAIR VISUAL ACCURACY OF SPECIFIED COLORS.

CONCEPT RENDERING





**3.6 MONITOR 55" WALL MOUNT**

**ANTHONY  
JAMES  
PARTNERS**

3900 WESTERRE PARKWAY, SUITE 300 804.727.0070  
 RICHMOND, VIRGINIA 23233 www.anthonijamespartners.com

\*ASSET REQUIRES FIELD SURVEY TO DETERMINE SIZING PRIOR TO FABRICATION OR INSTALLATION. DIMENSIONS NOTED IN THIS DOCUMENT ARE FOR ESTIMATION PURPOSES ONLY. VENDOR IS RESPONSIBLE FOR ANY INCONSISTENCIES BETWEEN CONCEPTS AND FIELD-VERIFIED DIMENSIONS.

THIS ARTWORK IS PROTECTED UNDER FEDERAL AND INTERNATIONAL COPYRIGHT LAW. EXPRESS PERMISSION FROM ANTHONY JAMES PARTNERS (AJP) IS REQUIRED FOR REPRODUCTION. RENDERINGS ARE FOR THE EXCLUSIVE USE OF DESIGNATED CLIENTS, ASSOCIATES AND AJP. THESE RENDERINGS DO NOT REPRESENT FABRICATION OR STRUCTURAL ENGINEER CERTIFIED OR STAMPED DOCUMENTS. MONITOR AND/OR PRINTER CALIBRATION MAY IMPAIR VISUAL ACCURACY OF SPECIFIED COLORS.

**MUST BE FIELD VERIFIED\***

**PENNSYLVANIA CONVENTION CENTER**

CONCEPT RENDERING

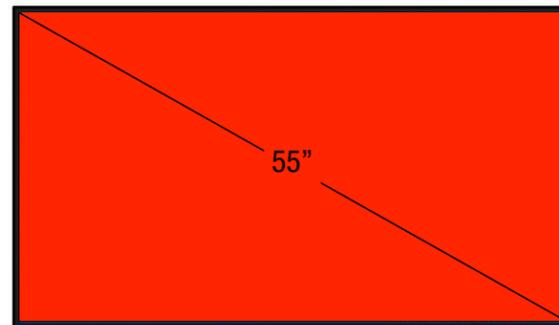

○ LCD LAYOUT  
3/4" = 1'-0"

### 3.6 MONITOR 55" WALL MOUNT

**ANTHONY  
JAMES  
PARTNERS**

3900 WESTERRE PARKWAY, SUITE 300 804.727.0070  
RICHMOND, VIRGINIA 23233 www.anthonyjamespartners.com

\*ASSET REQUIRES FIELD SURVEY TO DETERMINE SIZING PRIOR TO FABRICATION OR INSTALLATION. DIMENSIONS NOTED IN THIS DOCUMENT ARE FOR ESTIMATION PURPOSES ONLY. VENDOR IS RESPONSIBLE FOR ANY INCONSISTENCIES BETWEEN CONCEPTS AND FIELD-VERIFIED DIMENSIONS.

\* LED IS OUT OF 16:9 RATIO PER OWNER DIRECTION

**MUST BE FIELD VERIFIED\***

PENNSYLVANIA CONVENTION CENTER

THIS ARTWORK IS PROTECTED UNDER FEDERAL AND INTERNATIONAL COPYRIGHT LAW. EXPRESS PERMISSION FROM ANTHONY JAMES PARTNERS (AJP) IS REQUIRED FOR REPRODUCTION. RENDERINGS ARE FOR THE EXCLUSIVE USE OF DESIGNATED CLIENTS, ASSOCIATES AND AJP. THESE RENDERINGS DO NOT REPRESENT FABRICATION OR STRUCTURAL ENGINEER CERTIFIED OR STAMPED DOCUMENTS. MONITOR AND/OR PRINTER CALIBRATION MAY IMPAIR VISUAL ACCURACY OF SPECIFIED COLORS.

CONCEPT RENDERING



### 3.6A MONITOR 55" WALL MOUNT PORTRAIT

**ANTHONY  
JAMES  
PARTNERS**

3900 WESTERRE PARKWAY, SUITE 300 804.727.0070  
RICHMOND, VIRGINIA 23233 [www.anthonyjamespartners.com](http://www.anthonyjamespartners.com)

\*ASSET REQUIRES FIELD SURVEY TO DETERMINE SIZING PRIOR TO FABRICATION OR INSTALLATION. DIMENSIONS NOTED IN THIS DOCUMENT ARE FOR ESTIMATION PURPOSES ONLY. VENDOR IS RESPONSIBLE FOR ANY INCONSISTENCIES BETWEEN CONCEPTS AND FIELD-VERIFIED DIMENSIONS.

THIS ARTWORK IS PROTECTED UNDER FEDERAL AND INTERNATIONAL COPYRIGHT LAW. EXPRESS PERMISSION FROM ANTHONY JAMES PARTNERS (AJP) IS REQUIRED FOR REPRODUCTION. RENDERINGS ARE FOR THE EXCLUSIVE USE OF DESIGNATED CLIENTS, ASSOCIATES AND AJP. THESE RENDERINGS DO NOT REPRESENT FABRICATION OR STRUCTURAL ENGINEER CERTIFIED OR STAMPED DOCUMENTS. MONITOR AND/OR PRINTER CALIBRATION MAY IMPAIR VISUAL ACCURACY OF SPECIFIED COLORS.

**MUST BE FIELD VERIFIED\***

PENNSYLVANIA CONVENTION CENTER

CONCEPT RENDERING

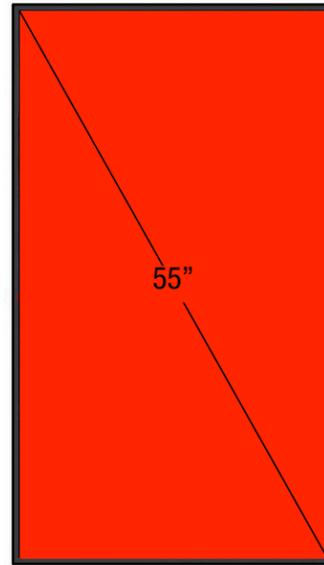

○ LCD LAYOUT  
3/4" = 1'-0"

### 3.6A MONITOR 55" WALL MOUNT PORTRAIT

\* LED IS OUT OF 16:9 RATIO PER OWNER DIRECTION

**MUST BE FIELD VERIFIED\***

**ANTHONY  
JAMES  
PARTNERS**

3900 WESTERRE PARKWAY, SUITE 300 804.727.0070  
RICHMOND, VIRGINIA 23233 www.anthonyjamespartners.com

\*ASSET REQUIRES FIELD SURVEY TO DETERMINE SIZING PRIOR TO FABRICATION OR INSTALLATION. DIMENSIONS NOTED IN THIS DOCUMENT ARE FOR ESTIMATION PURPOSES ONLY. VENDOR IS RESPONSIBLE FOR ANY INCONSISTENCIES BETWEEN CONCEPTS AND FIELD-VERIFIED DIMENSIONS.

PENNSYLVANIA CONVENTION CENTER

THIS ARTWORK IS PROTECTED UNDER FEDERAL AND INTERNATIONAL COPYRIGHT LAW. EXPRESS PERMISSION FROM ANTHONY JAMES PARTNERS (AJP) IS REQUIRED FOR REPRODUCTION. RENDERINGS ARE FOR THE EXCLUSIVE USE OF DESIGNATED CLIENTS, ASSOCIATES AND AJP. THESE RENDERINGS DO NOT REPRESENT FABRICATION OR STRUCTURAL ENGINEER CERTIFIED OR STAMPED DOCUMENTS. MONITOR AND/OR PRINTER CALIBRATION MAY IMPAIR VISUAL ACCURACY OF SPECIFIED COLORS.

CONCEPT RENDERING



### 3.7 RIBBON TERRACE BALLROOM

**ANTHONY  
JAMES  
PARTNERS**

3900 WESTERRE PARKWAY, SUITE 300 804.727.0070  
RICHMOND, VIRGINIA 23233 www.anthonijamespartners.com

\*ASSET REQUIRES FIELD SURVEY TO DETERMINE SIZING PRIOR TO FABRICATION OR INSTALLATION. DIMENSIONS NOTED IN THIS DOCUMENT ARE FOR ESTIMATION PURPOSES ONLY. VENDOR IS RESPONSIBLE FOR ANY INCONSISTENCIES BETWEEN CONCEPTS AND FIELD-VERIFIED DIMENSIONS.

THIS ARTWORK IS PROTECTED UNDER FEDERAL AND INTERNATIONAL COPYRIGHT LAW. EXPRESS PERMISSION FROM ANTHONY JAMES PARTNERS (AJP) IS REQUIRED FOR REPRODUCTION. RENDERINGS ARE FOR THE EXCLUSIVE USE OF DESIGNATED CLIENTS, ASSOCIATES AND AJP. THESE RENDERINGS DO NOT REPRESENT FABRICATION OR STRUCTURAL ENGINEER CERTIFIED OR STAMPED DOCUMENTS. MONITOR AND/OR PRINTER CALIBRATION MAY IMPAIR VISUAL ACCURACY OF SPECIFIED COLORS.

**MUST BE FIELD VERIFIED\***

PENNSYLVANIA CONVENTION CENTER

CONCEPT RENDERING

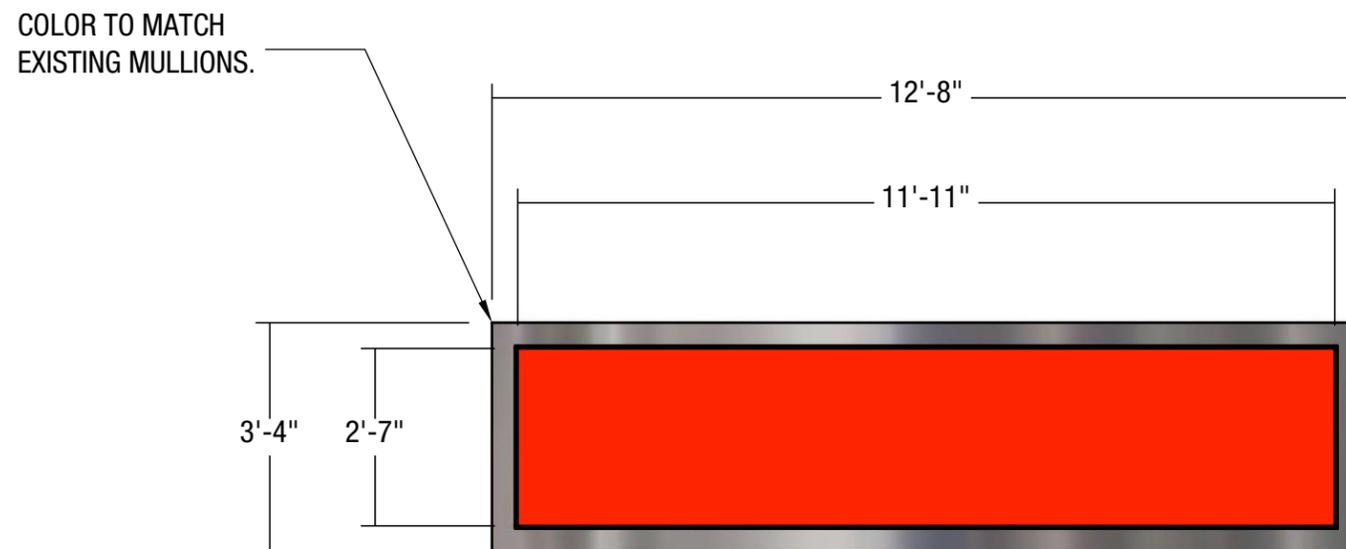

○ LED LAYOUT  
3/8" = 1'-0"

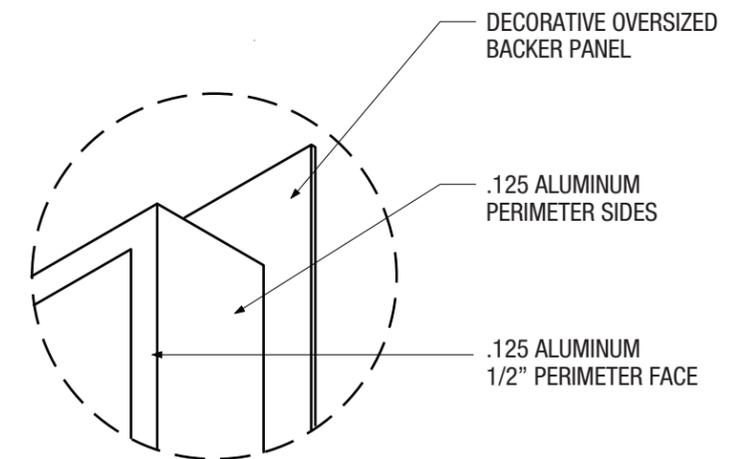

○ LED DETAIL (SURROUND)  
NTS

\* LED IS OUT OF 16:9 RATIO PER OWNER DIRECTION

**MUST BE FIELD VERIFIED\***

### 3.7 RIBBON HALL ENTRANCE

**ANTHONY  
JAMES  
PARTNERS**

3900 WESTERRE PARKWAY, SUITE 300 RICHMOND, VIRGINIA 23233 804.727.0070  
www.anthonyjamespartners.com

\*ASSET REQUIRES FIELD SURVEY TO DETERMINE SIZING PRIOR TO FABRICATION OR INSTALLATION. DIMENSIONS NOTED IN THIS DOCUMENT ARE FOR ESTIMATION PURPOSES ONLY. VENDOR IS RESPONSIBLE FOR ANY INCONSISTENCIES BETWEEN CONCEPTS AND FIELD-VERIFIED DIMENSIONS.

PENNSYLVANIA CONVENTION CENTER

THIS ARTWORK IS PROTECTED UNDER FEDERAL AND INTERNATIONAL COPYRIGHT LAW. EXPRESS PERMISSION FROM ANTHONY JAMES PARTNERS (AJP) IS REQUIRED FOR REPRODUCTION. RENDERINGS ARE FOR THE EXCLUSIVE USE OF DESIGNATED CLIENTS, ASSOCIATES AND AJP. THESE RENDERINGS DO NOT REPRESENT FABRICATION OR STRUCTURAL ENGINEER CERTIFIED OR STAMPED DOCUMENTS. MONITOR AND/OR PRINTER CALIBRATION MAY IMPAIR VISUAL ACCURACY OF SPECIFIED COLORS.

CONCEPT RENDERING



### 3.9 SIGNAGE MEETING ROOMS

**ANTHONY  
JAMES  
PARTNERS**

3900 WESTERRE PARKWAY, SUITE 300  
RICHMOND, VIRGINIA 23233

804.727.0070  
[www.anthonyjamespartners.com](http://www.anthonyjamespartners.com)

\*ASSET REQUIRES FIELD SURVEY TO DETERMINE SIZING PRIOR TO FABRICATION OR INSTALLATION. DIMENSIONS NOTED IN THIS DOCUMENT ARE FOR ESTIMATION PURPOSES ONLY. VENDOR IS RESPONSIBLE FOR ANY INCONSISTENCIES BETWEEN CONCEPTS AND FIELD-VERIFIED DIMENSIONS.

THIS ARTWORK IS PROTECTED UNDER FEDERAL AND INTERNATIONAL COPYRIGHT LAW. EXPRESS PERMISSION FROM ANTHONY JAMES PARTNERS (AJP) IS REQUIRED FOR REPRODUCTION. RENDERINGS ARE FOR THE EXCLUSIVE USE OF DESIGNATED CLIENTS, ASSOCIATES AND AJP. THESE RENDERINGS DO NOT REPRESENT FABRICATION OR STRUCTURAL ENGINEER CERTIFIED OR STAMPED DOCUMENTS. MONITOR AND/OR PRINTER CALIBRATION MAY IMPAIR VISUAL ACCURACY OF SPECIFIED COLORS.

**MUST BE FIELD VERIFIED\***

PENNSYLVANIA CONVENTION CENTER

CONCEPT RENDERING

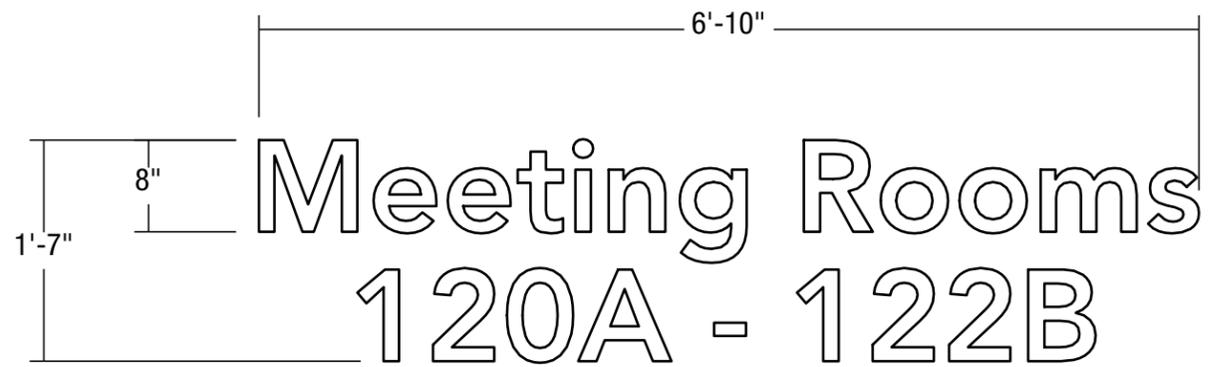

○ **LETTER LAYOUT**  
3/4" = 1'-0"



○ **LETTER LAYOUT SIDE**  
3/4" = 1'-0"

### 3.9 SIGNAGE MEETING ROOMS

**ANTHONY  
JAMES  
PARTNERS**

3900 WESTERRE PARKWAY, SUITE 300 804.727.0070  
RICHMOND, VIRGINIA 23233 www.anthonyjamespartners.com

\*ASSET REQUIRES FIELD SURVEY TO DETERMINE SIZING PRIOR TO FABRICATION OR INSTALLATION. DIMENSIONS NOTED IN THIS DOCUMENT ARE FOR ESTIMATION PURPOSES ONLY. VENDOR IS RESPONSIBLE FOR ANY INCONSISTENCIES BETWEEN CONCEPTS AND FIELD-VERIFIED DIMENSIONS.

**MUST BE FIELD VERIFIED\***

PENNSYLVANIA CONVENTION CENTER

THIS ARTWORK IS PROTECTED UNDER FEDERAL AND INTERNATIONAL COPYRIGHT LAW. EXPRESS PERMISSION FROM ANTHONY JAMES PARTNERS (AJP) IS REQUIRED FOR REPRODUCTION. RENDERINGS ARE FOR THE EXCLUSIVE USE OF DESIGNATED CLIENTS, ASSOCIATES AND AJP. THESE RENDERINGS DO NOT REPRESENT FABRICATION OR STRUCTURAL ENGINEER CERTIFIED OR STAMPED DOCUMENTS. MONITOR AND/OR PRINTER CALIBRATION MAY IMPAIR VISUAL ACCURACY OF SPECIFIED COLORS.

CONCEPT RENDERING



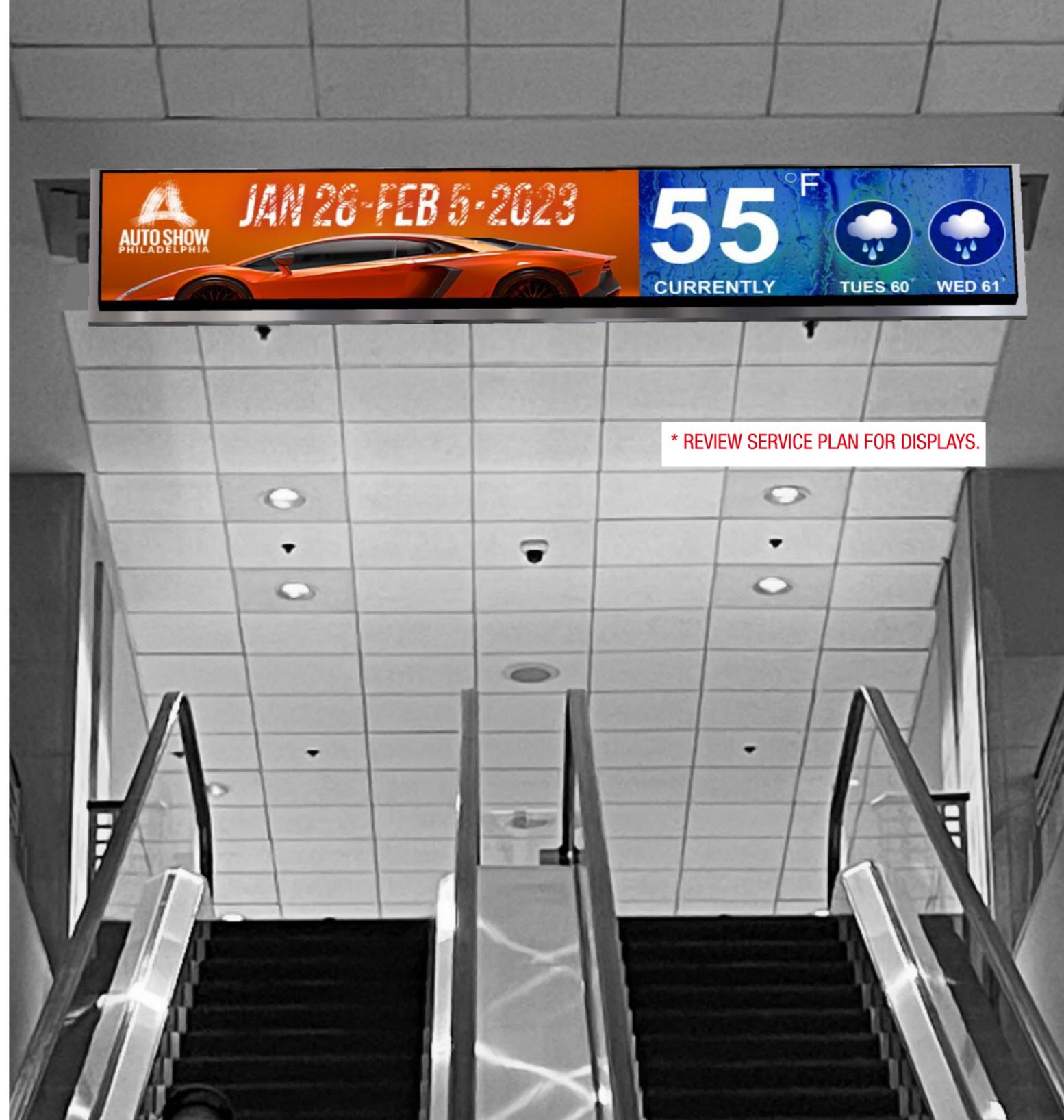

\* REVIEW SERVICE PLAN FOR DISPLAYS.

### 3.8 DISPLAY WAYFINDING OVERHEAD DOUBLE-SIDED LED ESCALATOR

**ANTHONY  
JAMES  
PARTNERS**

3900 WESTERRE PARKWAY, SUITE 300 804.727.0070  
RICHMOND, VIRGINIA 23233 www.anthonijamespartners.com

\*ASSET REQUIRES FIELD SURVEY TO DETERMINE SIZING PRIOR TO FABRICATION OR INSTALLATION. DIMENSIONS NOTED IN THIS DOCUMENT ARE FOR ESTIMATION PURPOSES ONLY. VENDOR IS RESPONSIBLE FOR ANY INCONSISTENCIES BETWEEN CONCEPTS AND FIELD-VERIFIED DIMENSIONS.

THIS ARTWORK IS PROTECTED UNDER FEDERAL AND INTERNATIONAL COPYRIGHT LAW. EXPRESS PERMISSION FROM ANTHONY JAMES PARTNERS (AJP) IS REQUIRED FOR REPRODUCTION. RENDERINGS ARE FOR THE EXCLUSIVE USE OF DESIGNATED CLIENTS, ASSOCIATES AND AJP. THESE RENDERINGS DO NOT REPRESENT FABRICATION OR STRUCTURAL ENGINEER CERTIFIED OR STAMPED DOCUMENTS. MONITOR AND/OR PRINTER CALIBRATION MAY IMPAIR VISUAL ACCURACY OF SPECIFIED COLORS.

**MUST BE FIELD VERIFIED\***

PENNSYLVANIA CONVENTION CENTER

CONCEPT RENDERING

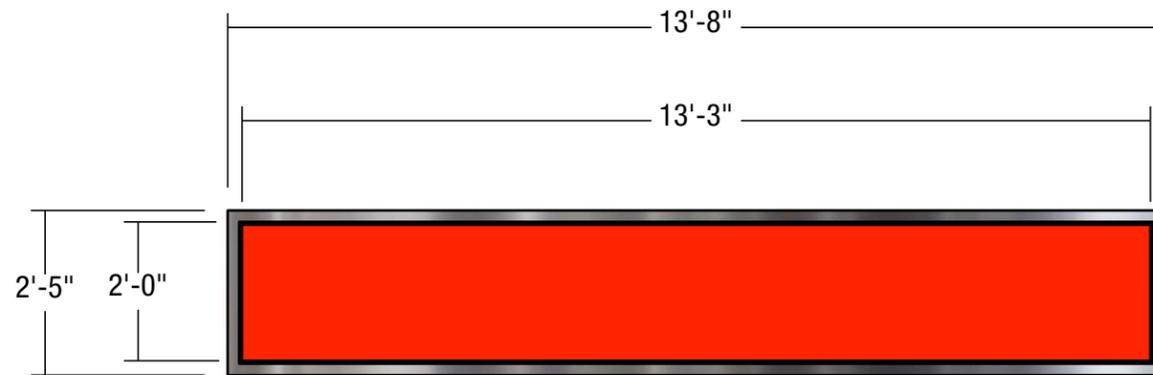

○ LED LAYOUT  
3/8" = 1'-0"



○ LED PROFILE  
3/8" = 1'-0"

### 3.8 DISPLAY WAYFINDING OVERHEAD DOUBLE-SIDED LED ESCALATOR

**ANTHONY  
JAMES  
PARTNERS**

3900 WESTERRE PARKWAY, SUITE 300 804.727.0070  
RICHMOND, VIRGINIA 23233 www.anthonyjamespartners.com

\*ASSET REQUIRES FIELD SURVEY TO DETERMINE SIZING PRIOR TO FABRICATION OR INSTALLATION. DIMENSIONS NOTED IN THIS DOCUMENT ARE FOR ESTIMATION PURPOSES ONLY. VENDOR IS RESPONSIBLE FOR ANY INCONSISTENCIES BETWEEN CONCEPTS AND FIELD-VERIFIED DIMENSIONS.

**MUST BE FIELD VERIFIED\***

PENNSYLVANIA CONVENTION CENTER

THIS ARTWORK IS PROTECTED UNDER FEDERAL AND INTERNATIONAL COPYRIGHT LAW. EXPRESS PERMISSION FROM ANTHONY JAMES PARTNERS (AJP) IS REQUIRED FOR REPRODUCTION. RENDERINGS ARE FOR THE EXCLUSIVE USE OF DESIGNATED CLIENTS, ASSOCIATES AND AJP. THESE RENDERINGS DO NOT REPRESENT FABRICATION OR STRUCTURAL ENGINEER CERTIFIED OR STAMPED DOCUMENTS. MONITOR AND/OR PRINTER CALIBRATION MAY IMPAIR VISUAL ACCURACY OF SPECIFIED COLORS.

CONCEPT RENDERING



### 3.10 MONITOR SINGLE SIDED KIOSK

**ANTHONY  
JAMES  
PARTNERS**

3900 WESTERRE PARKWAY, SUITE 300 RICHMOND, VIRGINIA 23233 804.727.0070  
www.anthonijamespartners.com

\*ASSET REQUIRES FIELD SURVEY TO DETERMINE SIZING PRIOR TO FABRICATION OR INSTALLATION. DIMENSIONS NOTED IN THIS DOCUMENT ARE FOR ESTIMATION PURPOSES ONLY. VENDOR IS RESPONSIBLE FOR ANY INCONSISTENCIES BETWEEN CONCEPTS AND FIELD-VERIFIED DIMENSIONS.

THIS ARTWORK IS PROTECTED UNDER FEDERAL AND INTERNATIONAL COPYRIGHT LAW. EXPRESS PERMISSION FROM ANTHONY JAMES PARTNERS (AJP) IS REQUIRED FOR REPRODUCTION. RENDERINGS ARE FOR THE EXCLUSIVE USE OF DESIGNATED CLIENTS, ASSOCIATES AND AJP. THESE RENDERINGS DO NOT REPRESENT FABRICATION OR STRUCTURAL ENGINEER CERTIFIED OR STAMPED DOCUMENTS. MONITOR AND/OR PRINTER CALIBRATION MAY IMPAIR VISUAL ACCURACY OF SPECIFIED COLORS.

**MUST BE FIELD VERIFIED\***

PENNSYLVANIA CONVENTION CENTER

CONCEPT RENDERING

STEEL SURROUND

55" LED MONITOR

CHANNEL LOGO  
LED ILLUMINATED

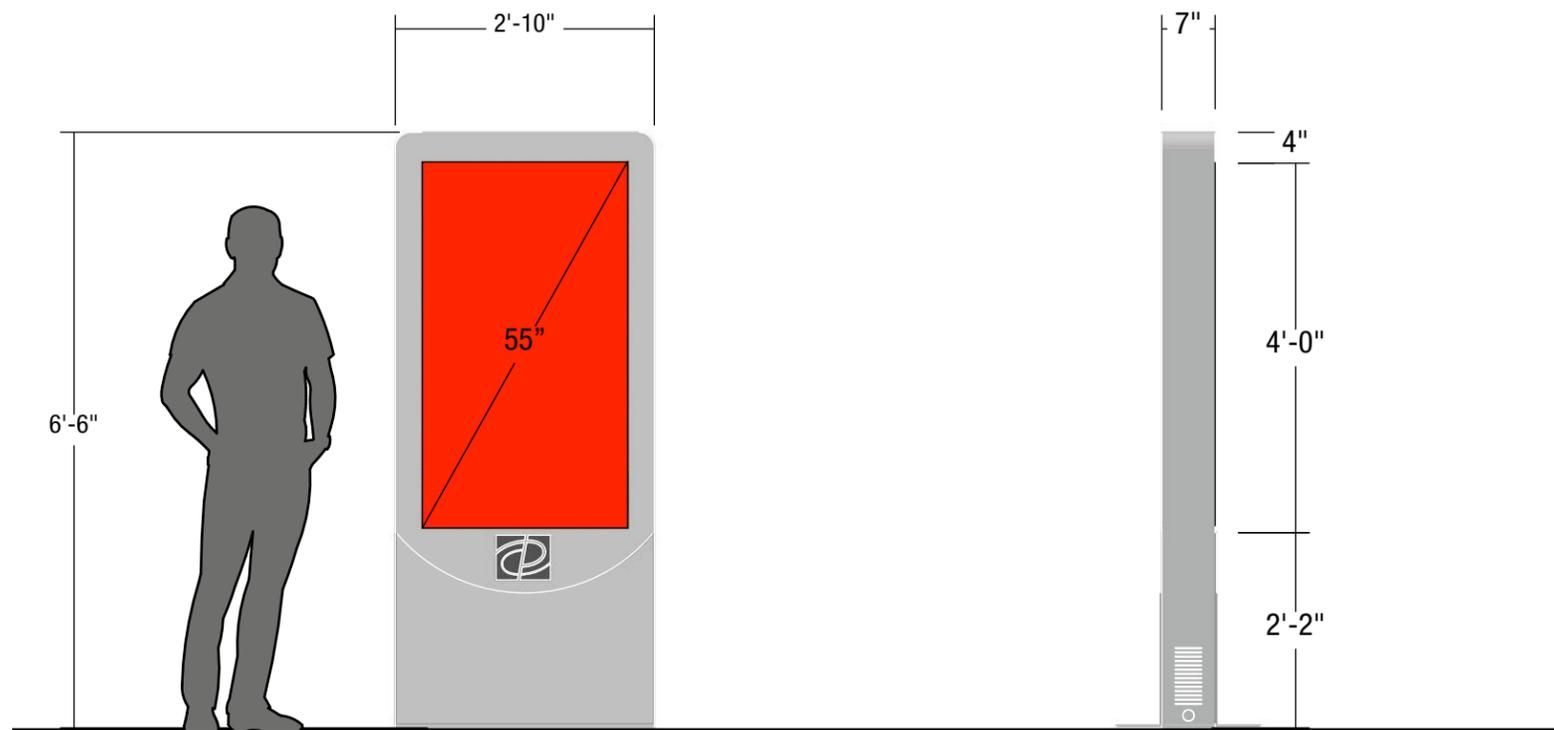

**LCD KIOSK LAYOUT**  
1/2" = 1'-0"

### 3.10 MONITOR SINGLE SIDED KIOSK

**ANTHONY  
JAMES  
PARTNERS**

3900 WESTERRE PARKWAY, SUITE 300 RICHMOND, VIRGINIA 23233 804.727.0070  
www.anthonyjamespartners.com

\*ASSET REQUIRES FIELD SURVEY TO DETERMINE SIZING PRIOR TO FABRICATION OR INSTALLATION. DIMENSIONS NOTED IN THIS DOCUMENT ARE FOR ESTIMATION PURPOSES ONLY. VENDOR IS RESPONSIBLE FOR ANY INCONSISTENCIES BETWEEN CONCEPTS AND FIELD-VERIFIED DIMENSIONS.

**MUST BE FIELD VERIFIED\***

PENNSYLVANIA CONVENTION CENTER

THIS ARTWORK IS PROTECTED UNDER FEDERAL AND INTERNATIONAL COPYRIGHT LAW. EXPRESS PERMISSION FROM ANTHONY JAMES PARTNERS (AJP) IS REQUIRED FOR REPRODUCTION. RENDERINGS ARE FOR THE EXCLUSIVE USE OF DESIGNATED CLIENTS, ASSOCIATES AND AJP. THESE RENDERINGS DO NOT REPRESENT FABRICATION OR STRUCTURAL ENGINEER CERTIFIED OR STAMPED DOCUMENTS. MONITOR AND/OR PRINTER CALIBRATION MAY IMPAIR VISUAL ACCURACY OF SPECIFIED COLORS.

CONCEPT RENDERING