

GENERAL NOTES:

- 1.CONTRACTOR MUST FAMILIARIZE THEMSELVES WITH THE SITE PRIOR TO SUBMITTING FINAL BID.
- 2.CONTRACTOR MUST COORDINATE ALL WORK WITH THE ONSITE ENGINEER OR HIS DESIGNEE, IN REFERENCE TO MOBILIZATION AND DE-MOBILIZATION, ONSITE MATERIAL DELIVERY.
- 3.CONTRACTOR IS RESPONSIBLE FOR THE FIELD VERIFY ALL DIMENSIONS AND IS RESPONSIBLE FOR BIDDING, MATERIAL FABRICATION AND THE FINAL INSTALLATION. DO NOT SCALE DRAWING.
- 4.THE CONTRACTOR SHALL INSTALL AND MAINTAIN ALL NECESSARY COVERINGS, PROTECTIVE ENCLOSURE, TEMPORARY DOORS AND PARTITIONS AND A DUST BARRIER TO PROTECT ALL OCCUPANTS AND EXISTING WORK AND FINISHES TO REMAIN. LOCATION OF SUCH PROTECTION SHALL BE VERIFIED WITH THE ENGINEER FOR CONFORMANCE PRIOR TO COMMENCING WORK AND IN COORDINATION WITH PROGRESSION OF WORK SCHEDULE PERFORMED WORKED IN A MANNER THAT WILL BE AVOID HAZARDS TO PERSONS IN THE ADJACENT AREAS AND THAT WON'T INTERFERE WITH WORK OR PASSAGE T ANY OF THESE AREAS. REPAIR AND REPLACE ANY DAMAGE CAUSED BY IMPROPER PROTECTION AT NO ADDITIONAL COST TO THE OWNER.
- 5.WORK DAMAGED DURING CONSTRUCTION OR NOT CONFORMING TO SPECIFIED STANDARDS, TOLERANCES OR MANUFACTURERS INSTRUCTIONS FOR INSTALLATION SHALL BE REPLACED, BY THE CONTRACTOR, AT NO ADDITIONAL COST TO THE OWNER.
- 6.CONTRACTOR SHALL COMPLY WITH MANUFACTURERS INSTRUCTIONS WHEN RELOCATING AND / OR INSTALLING ANY EQUIPMENT AND FURNISHINGS.
- 7.THE CONTRACTOR SHALL PERFORM ALL CUTTING AND WELDING IN COMPLIANCE WITH THE PUBLISHED STANDARD OF NFPA. THE CONTRACTOR SHALL PROVIDE FIRE WATCHES FOR ALL CUTTING, GRINDING, AND WELDING OPERATIONS. THE TRAINING OF THESE FIRE WATCHERS AND THE USE OF THE CONTRACTOR'S SUPPLIED FIRE EXTINGUISHERS IS THE RESPONSIBILITY OF THE CONTRACTOR.
- 8.REPAIR AND OR REPLACE EXISTING ITEMS NOT SCHEDULED OR NOTED TO BE DEMOLISHED, AND NOT SPECIFIED TO BE REMOVED, BUT WHICH BECAME DAMAGED DURING THE PROGRESS OF THE WORK. MAKE ANY AND ALL SUCH REPAIRS, REPLACEMENT AND MODIFICATIONS TO RESTORE THE DAMAGED ITEMS TO THEIR OPERATIONAL CONDITION AT THE TIME OF DAMAGE, OF THE SPECIFICATION OF AND AT NO ADDITIONAL COST TO THE OWNER.
- 9.THE DIAGRAMMATIC DRAWING INDICATES A FULL FREE STANDING 8X10 FEET DOOR OPENING. THE SAME DRAWINGS INDICATE A 8X10 WITH AN ELEVATED DOCK SPACE.

APPLICABLE CODES:

2018 INTERNATIONAL BUILDING CODE
 2018 INTERNATIONAL ENERGY CODE
 ICC/ANSI A117.1.2009
 UFAS
 NFPA-13

BASES OF DESIGN:

KELLY ENTRE MATIC: ARMORGUARD DOCK SEAL WITH HEAD 12”X10”X14”
 ADS-HP MFG.PER ATTACHED DOC. DOOR MUST BE SUBMITTED FOR APPROVAL BY THE ENGINEER ALL CHANGES TO THE DESIGN MUST BE DONE ONLY BY THE ENGINEER

SCOPE OF WORK:

DEMOLISH THE EXISTING LOADING DOCK SEAL CUSHION, CLIPS, ANCHORS, AND APPARATUSES

DEMOLISH EXISTING BUMPERS

ALL DEMOLISHED MATERIAL MUST BE REMOVED FROM THE SITE.

CLEAN ALL AREAS WHERE DEMOLISHED MATERIALS WERE REMOVED.

INSTALL THE DOOR SEAL PRODUCT AS PER MANUFACTURER SPECIFICATION

THE INSTALLED BUMPERS ARE TO BE REMOVED AND NEW AS SPECIFIED ARE TO BE INSTALLED IN THE SAME LOCATION AND AS SPECIFIED ON THE DOCUMENTS.

CONTRACTOR IS TO FAMILIARIZE SELF WITH THE PROJECT.
 ALL APPARATUSES PROVIDED BY THE MANUFACTURE MUST BE INSTALLED ACCORDINGLY.

ARCH/OWNER MUST REVIEW DOCUMENTS SUBMISSIONS FOR APPROVAL.
 AT MOCK UP LOCATIONS

- REMOVE 2X4 PT. LUMBER WT. HEAD CURTAIN
- SEAL ALL HOLES WT WATER RESISTANCE MATERIAL
- INSTALL NEW 9'-6”X12” TAPERED FR FRONT.
- BUMPERS TO BE 10”
- COLOR TO BE BLACK WT YELLOW GUIDE LINE AT SIDE UPRIGHTS ONLY
- PROCURE ADDITIONAL ANGLES/CLIPS TO INSTALL EACH DOOR.

General Notes		
1	DOOR REV	3/11/21
Checked by: DB		
No.	Revision/Issue	Date
Firm Name and Address		
Atrium International P.O. Box 653 Blue Bell Pa 19422 610-637-8812 donahuebailey@msn.com		
Project Name and Address		
Pennsylvania Convention Center DOCK SEAL DETAILS AND GENERAL NOTES		
Project	Date	Sheet
	10-26-2020	A-1
Scale	AS NOTED	

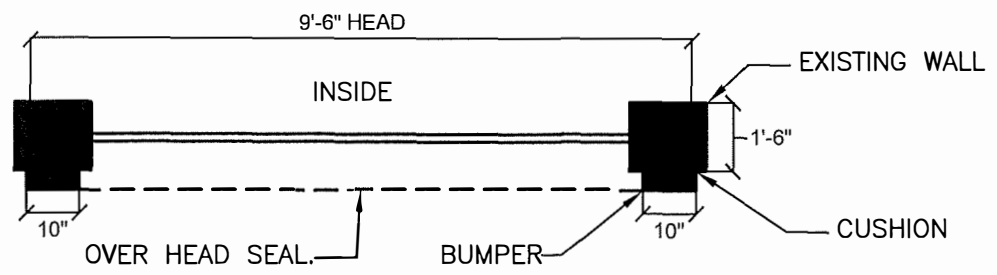

LOADING DOCK SEAL PLAN (CUSHION)
SCALE: 1/2"=1'-0"

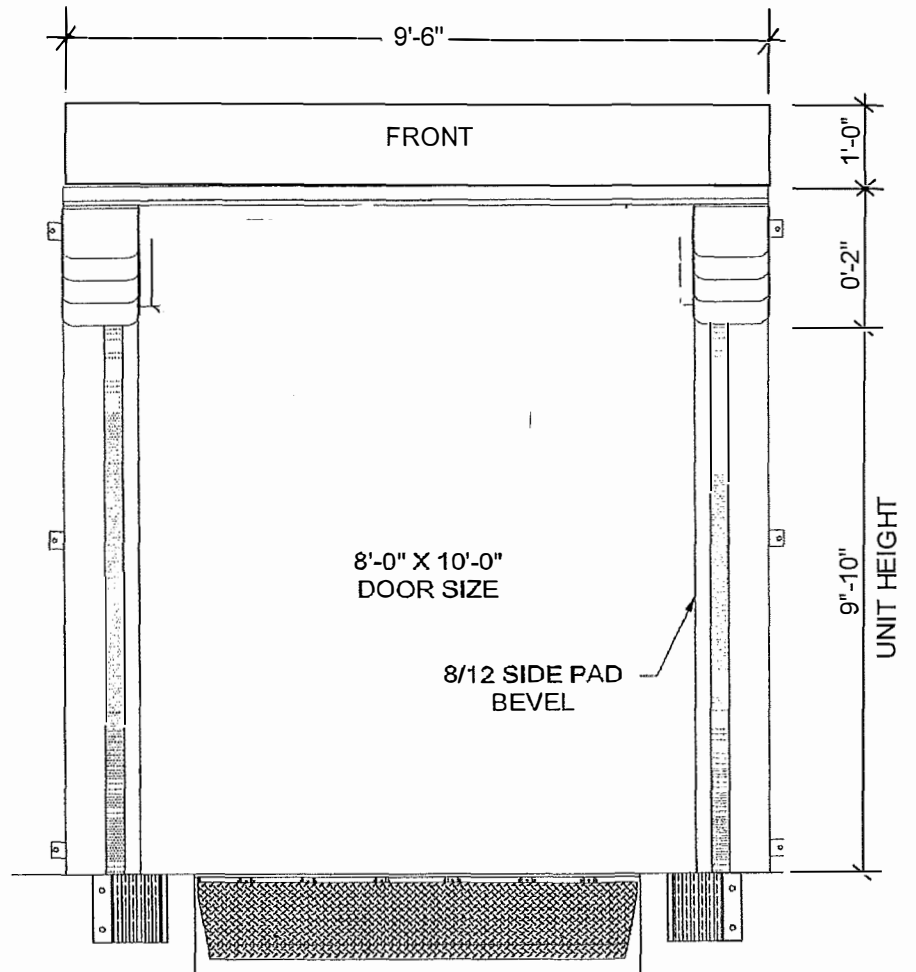

ELEVATION
SCALE: 1/2"=1'-0"

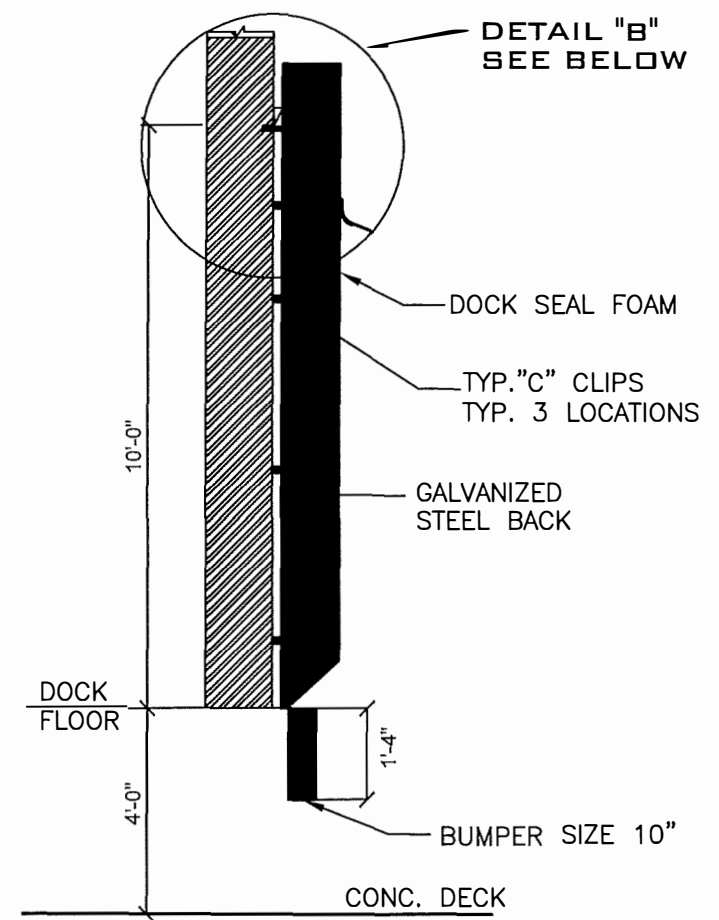

SECTION A-A
SCALE: 1/2"=1'-0"

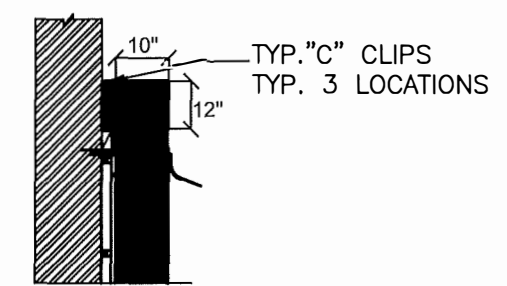

DETAIL "B"
SCALE: 1/2"=1'-0"

LOADING DOCK SCHEDULE

LOADING DOCK	DOCK DOOR NUMBERS	QUANTITY OF DOCK DOORS
UPPER LEVEL-A	15-28	14
UPPER LEVEL-B	8-14	7
UPPER LEVEL-C	1-7	7
UPPER LEVEL-D	49-61	13
LOWER LEVEL-F	29-38	10
LOWER LEVEL-G	45-48	4
LOWER LEVEL-H	39-44	6
TOTAL DOCK DOORS	---	61

General Notes
1. CONTRACTOR SHALL REPLACE ALL LOADING DOCK CUSHIONS AND BUMPERS. CONTRACTOR SHALL FIELD SURVEY ALL DOORS PRIOR TO BID TO BECOME FAMILIAR WITH THE PROJECT SCOPE. DOORS ARE AS LISTED IN DOOR SCHEDULE.

1 DOOR REV 3/11/21

Checked by: DB

Prep Name and Address
Atrium International
P.O. Box 653
Blue Bell Pa 19422
610-637-8812
donahuebailey@msn.com

Project Name and Address
Pennsylvania Convention Center
DOCK SEAL WITH CURTAIN LOADING DOCK

Project Date: 10-26-2020
Sheet: A-2
Date: AS NOTED

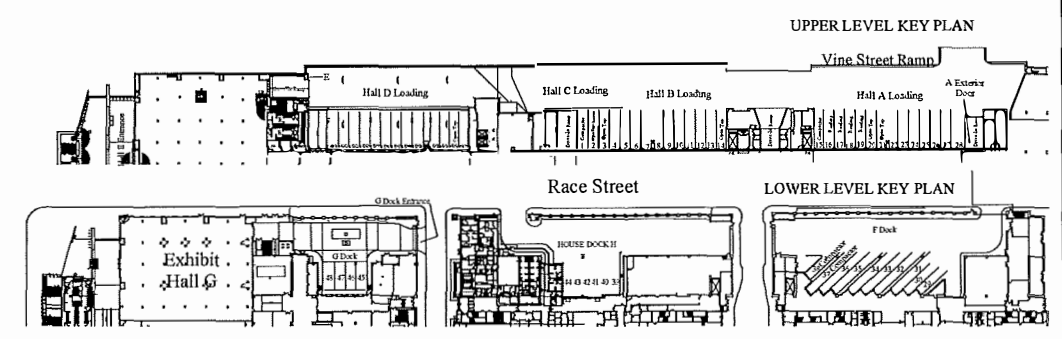

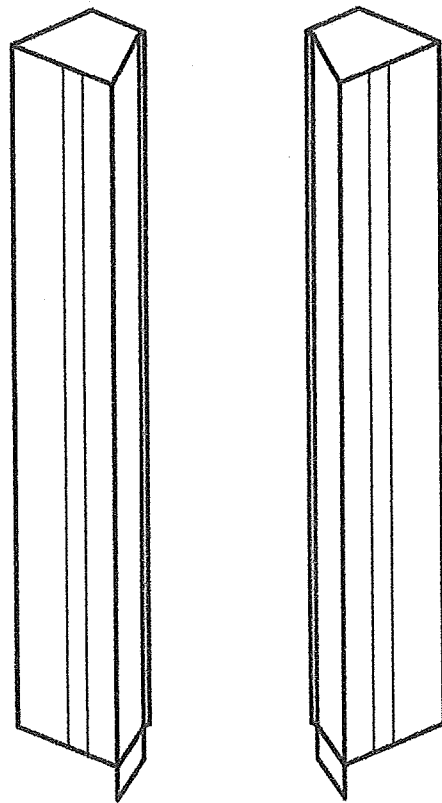

LEFT & RIGHT SIDE PAD
NO SCALE:

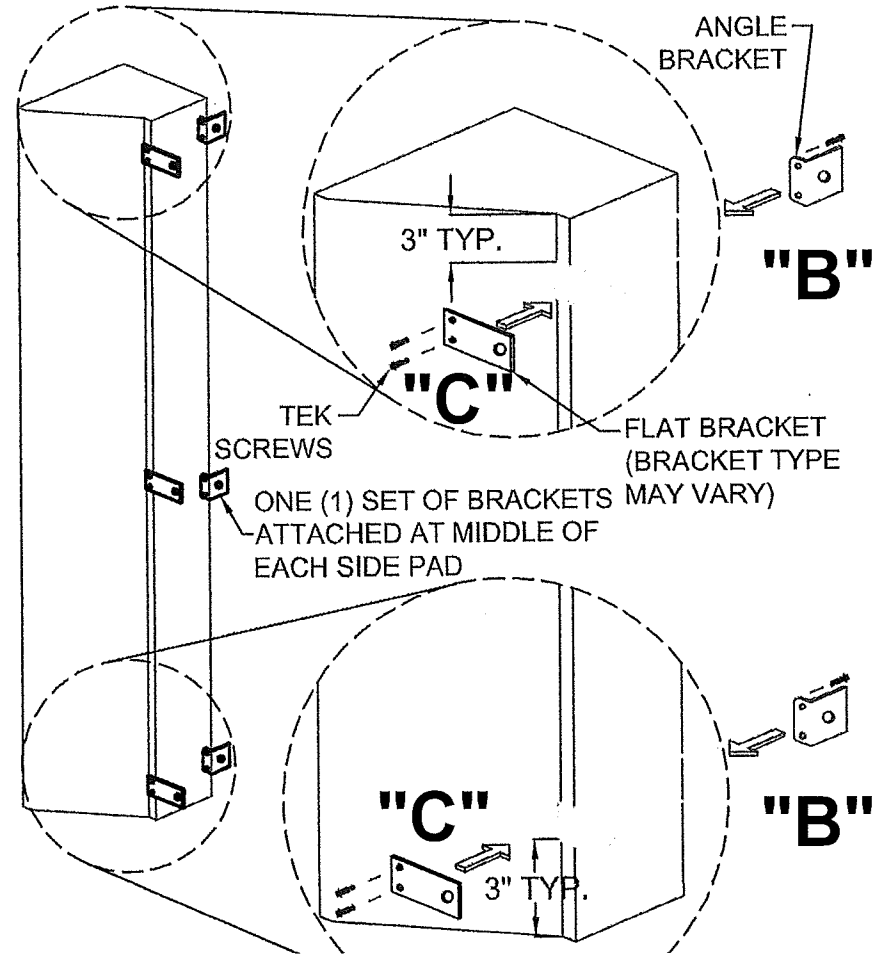

SIDE PAD MOUNTING BRACKET
NO SCALE:

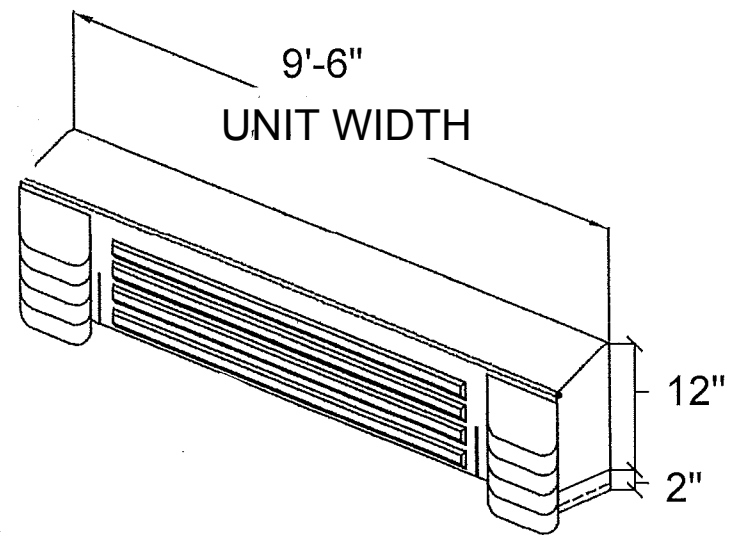

TOP PAD
NO SCALE:

LOADING DOCK SCHEDULE

LOADING DOCK	DOCK DOOR NUMBERS	QUANTITY OF DOCK DOORS
UPPER LEVEL-A	15-28	14
UPPER LEVEL-B	8-14	7
UPPER LEVEL-C	1-7	7
UPPER LEVEL-D	49-61	13
LOWER LEVEL-F	29-38	10
LOWER LEVEL-G	45-48	4
LOWER LEVEL-H	39-44	6
TOTAL DOCK DOORS	---	61

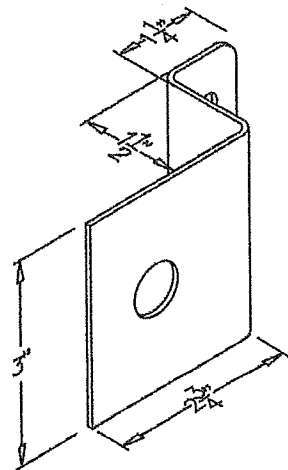

A 1-1/2" OFFSET
NO SCALE:

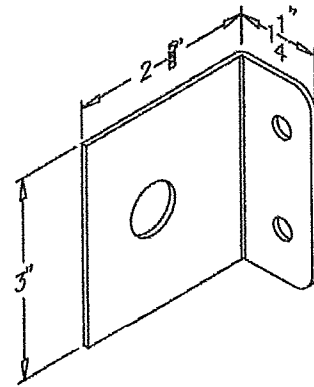

B ANGLE BRACKET
NO SCALE:

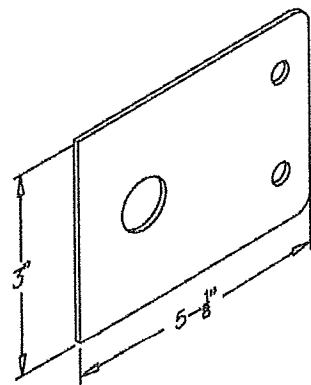

C FLAT BRACKET
NO SCALE:

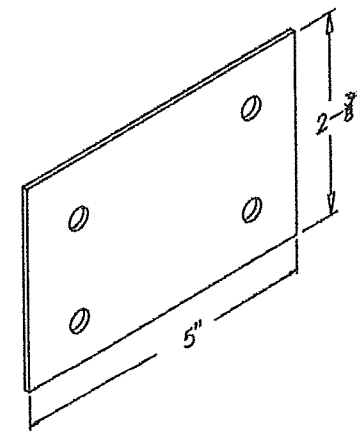

D BLOCK-OUT BRACKET
NO SCALE:

MOUNTING BRACKET DETAILS
NO SCALE:

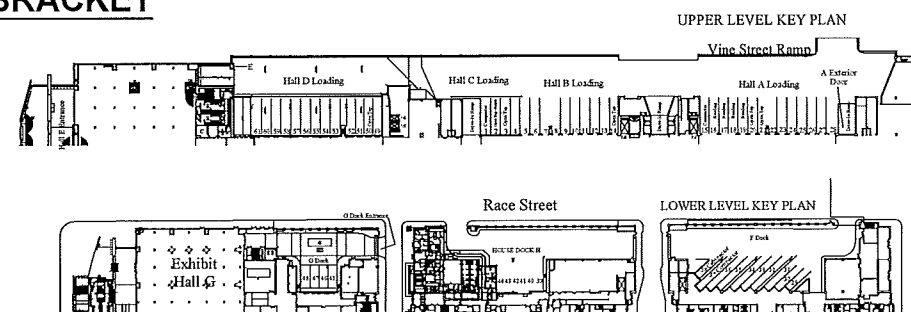

General Notes

- CONTRACTOR SHALL REPLACE ALL LOADING DOCK CUSHIONS AND BUMPERS. CONTRACTOR SHALL FIELD SURVEY ALL DOORS PRIOR TO BID TO BECOME FAMILIAR WITH THE PROJECT SCOPE. DOORS ARE AS LISTED IN DOOR SCHEDULE.

1 DOOR REV 3/11/21

Checked by: DB

No. Revisor/Issue Date

Rev Name and Address
Atrium International
P.O. Box 653
Blue Bell Pa 19422
610-637-8812
donahuebailey@msn.com

Project Name and Address
Pennsylvania Convention Center
DOCK SEAL DETAILS

Project Date: 10-26-2020
Sheet: A-3
Notes: AS NOTED